



FITTING INSTRUCTIONS

making everyday smoother



air suspension



- Increased comfort • Better driveability • More safety



PEUGEOT BOXER
FIAT DUCATO
CITROËN JUMPER
X250/X290

VB-FullAir 2C/4C
FRONT & REAR AXLE

FOR KIT:

1051807XXX

Revision table

New revision:	02	Old revision:	V1.0
Release date (yyyy-mm-dd):	2017-02-23		
Page (new):	Changes:		
all	New notation for revision number (00 .. 01 .. 02 etc)		
13, 15..17, 25	Additional information about alternative height sensor fitting		
16, 17	New U-bolts and nuts		
15, 17	New steel lock nut for bolt leaf spring bracket		
19	Paragraph 5.4 updated		
22	Pictures added for right hand version of bellow support		
26	Picture and additional information for location of air tank mounting bracket		
5, 37	New calibration support		
37	Reference to separate VB Calibration instructions		



© 2017 VB-Airsuspension B.V.

All rights reserved. No part of these publications may be reproduced and/or made public by printing, photocopying, microfilm or any other means whatsoever without the prior written consent of VB-Airsuspension B.V. This also applies to the accompanying drawings and diagrams.

Table of contents

1. Safety instructions	4
2. Fitting instructions	5
3. Explanatory notes to this manual	6
4. Compressor box and wiring harness	7
4.1 Compressor box	7
4.2 Wiring harness	8
4.3 Handbrake signal	11
4.4 Remote control	12
5. Fitting the air suspension kit for the rear axle	13
5.1 Preparations	13
5.2 Main spring	14
5.3 Upper cross beam	18
5.4 Panhard rod	19
5.5 Bump stops	21
5.6 Spare wheel bracket	21
5.7 Air springs	22
5.8 Height sensors	24
5.8.1 Height sensors option A	24
5.8.2 Height sensors option B	25
5.9 Shock absorbers	26
5.10 Air tank	26
5.11 Air tubes and height sensor cables	28
5.12 Warranty stickers	30
6. Fitting the air suspension kit to the front axle	31
6.1 Preparations	31
6.2 Suspension strut	32
6.3 Height sensors	33
6.4 Air tubes	36
6.5 Warranty stickers	36
7. Calibration	37
8. Checklist	38
8.1 Final checks	38
8.2 System functions	38
9. Appendix, other signals when Euro 4 model factory option is not present	39
9.1 Speed signal	39
9.2 15+ signal	39
10. Appendix, other signals when Euro 5 model factory option is not present	40
10.1 Speed signal	40
10.2 15+ signal	40
11. Electrical diagram	42

1. Safety instructions

Personal safety instructions

- Always wear suitable protective clothing and safety boots.
- Do not wear any rings, watches or loose clothing.
- Never carry loose items in your pockets.
- Tie back long hair.
- Never use broken tools. Only use tools for their intended purpose.
- Wear safety goggles.

General safety instructions

- If possible, always use a hydraulic ramp when carrying out the activities.
- If applicable, ensure that the vehicle is properly supported.
- Ensure that the vehicle cannot roll away.
- Improperly carried out installation can result in hazardous situations.

Symbols used

Caution



***When the warning symbol is shown, information is provided that is extremely important for the safety and/or health of those involved.
This symbol is also used for procedures that are critical for the correct installation of the air suspension kit.***

Tip



When the tip symbol is shown, information is provided that will help make installation of the air suspension kit simpler.

Torque



xx Nm

In this manual there is a check box next to each bolted joint showing the torque to be used when tightening the bolted joint.

2. Fitting instructions

This manual has been put together with great care and describes the steps for installing the air suspension indicated on the front page. However, the content of this manual is a snapshot view of the situation as at the time it was written.

VB-Airsuspension reserves the right to introduce technical changes at any time without warning.

The warranty is only valid if installation is carried out by a specialist workshop. Installation may only be carried out by suitably authorised personnel.

Staff must be experienced in working on light commercial vehicles, particularly in relation to electrics/electronics, pneumatics and general vehicle mechanics.

- Use vehicle workshop manuals where necessary.
- Always follow the vehicle manufacturer's conversion instructions, unless expressly stated otherwise in this manual.
- Keep workplace clean and tidy.
- Always tighten nuts and bolts to the specified torque.
- If alterations are made to the original anti-corrosion system, this must be remedied immediately. Use spray wax or a protective coating for this purpose.
- Always refit removed tubes and wires in the same way that they were originally fitted.
- Secure pipes and wires with a sufficient number of tie-wraps. Ensure that the wires cannot be placed under tension.
- The supply cable must be at least 100 mm away from the ABS/ESP block, the sensors and other control equipment.
- Ensure that there are no tight bends in air tubes and that they cannot be kinked or chafe against other parts.
- Never attach air tubes, wires or other parts to the vehicle's brake lines.
- Do not leave any tools, cleaning cloths or other materials behind after completing work.
- Use the checklist to check the air suspension system after fitting.
- Check the system for air tightness after fitting.
- Take the vehicle for a test drive after fitting.
- Ensure that the correct calibration supports are available. The correct calibration supports to be used with this kit are:

Axle:	Calibration height:	Order number:
Front axle	SHF = 260 mm	009 006 00 16
Rear axle	X = 125mm	009 006 00 13

- The air suspension kit is supplied for four corners. If a part is specifically for one corner, it is identified with a coloured sticker.

Colour	Description
Blue	Front left
Red	Front right
Green	Rear left
Black	Rear right

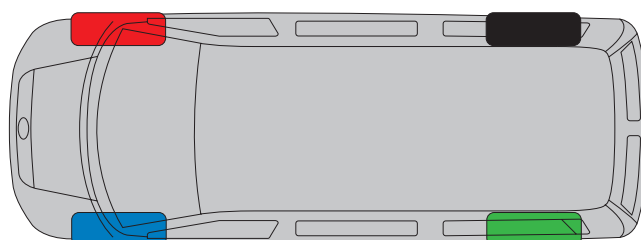

3. Explanatory notes to this manual

This manual is intended for the air suspension kit for the:

- Fiat Ducato X250 & X290
- Peugeot Boxer X250 & X290
- Citroën Jumper X250 & X290

This manual describes the steps for fitting the air suspension to the front and/or rear axle. Read through the appropriate sections for the kit ordered.

If you have a rear axle air suspension kit with item number 10518072XX, skip section 6.

If you have a front axle air suspension kit with item number 10518071XX, skip section 5.

If you have a front and rear axle air suspension kit with item number 10518074XX, read through all sections in this manual for fitting the front and rear axle air suspension.

Which axle?	Kit number	Section
Front axle	10518071XX	4, 6, 7
Rear axle	10518072XX	4, 5, 7
Front and rear axle	10518074XX	4, 5, 6, 7

This manual describes the steps for fitting the air suspension to X250 and X290 vehicles.. If the mounting steps required for a X250 differ from those for a X290 they will be clearly indicated with either **X250** or **X290**.



4. Compressor box and wiring harness

4.1 Compressor box

1. Open the battery housing under the driver's seat floor mat.



2. Loosen the marked bolts. Do not remove them.
3. Drill a $\varnothing 22$ mm hole in the place indicated.

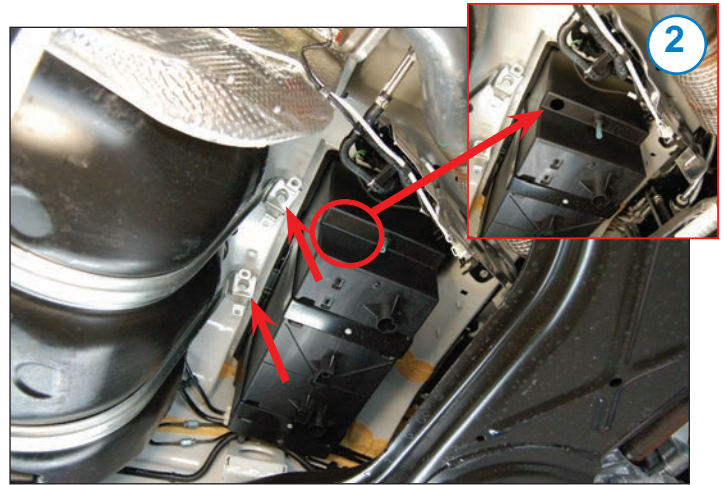

Ensure that no parts in the battery housing are damaged by drilling the hole.

4. Mount the compressor bracket below the bolts loosened in point 1. Slide the bracket under the bolts, looking from the rear.



Original fasteners



41 Nm

5. Fit the compressor bracket to the compressor suspension brackets.

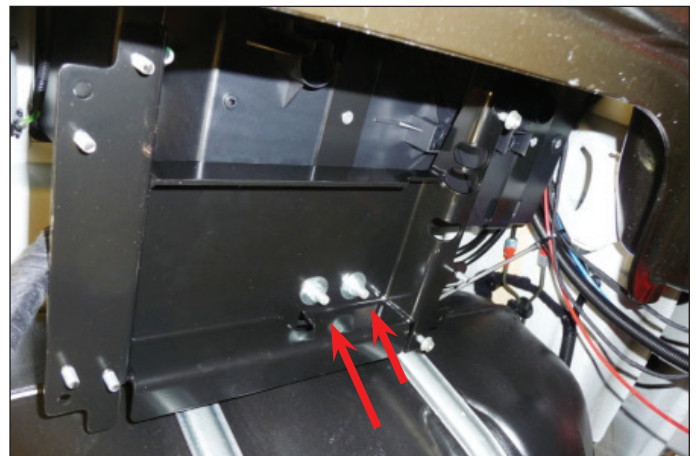

2 x lock nut

M8

2 x large washer

M8



15 Nm

6. Remove the cover from the compressor box.
7. Fit the compressor box to the bracket.
8. Tighten the bolts.

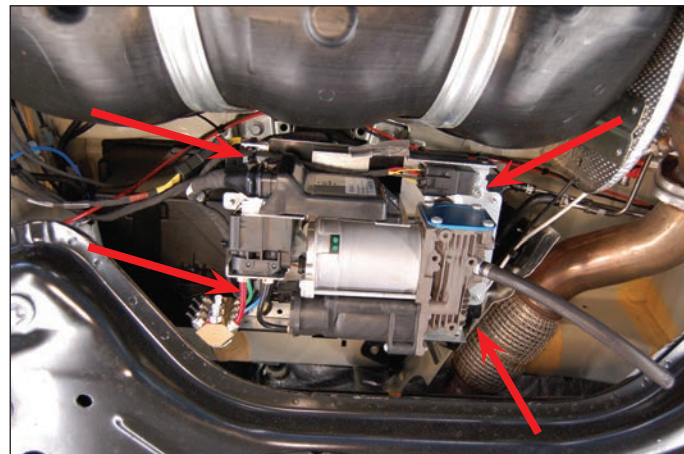

4 x flange lock nut

M6



8 Nm

4.2 Wiring harness

1. Remove the cover.
2. Remove the entry trim.

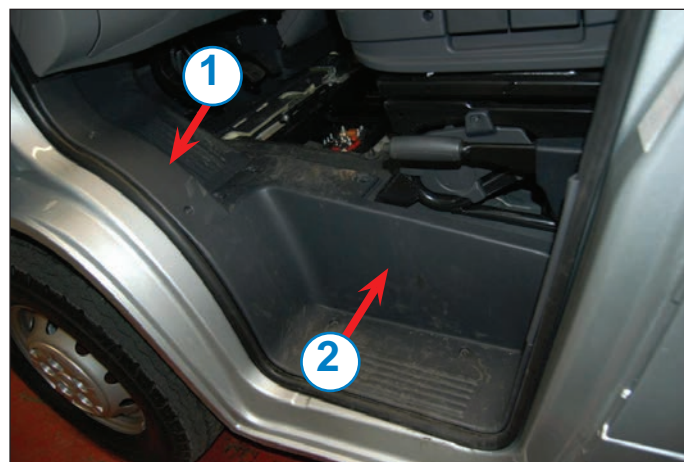

The vehicle must be fitted with factory option: 081
If not, go to item 3.
If not, go to section 6.

3. Remove the B-pillar cover on the right by unscrewing the marked bolts.



4. Remove the cover.
5. Remove the entry trim on the right-hand side.



- Route the VB wiring harness inside through the hole drilled in **section 4.1** point 3.

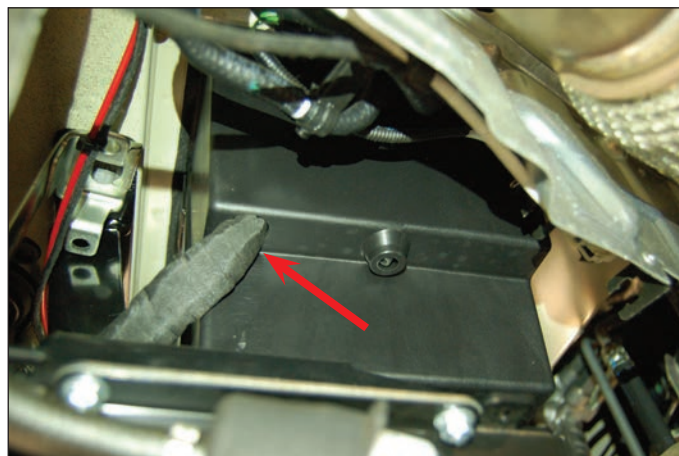

- Carefully pull the wire into the battery housing.
- Route the two cables with white connectors to the left around the battery.

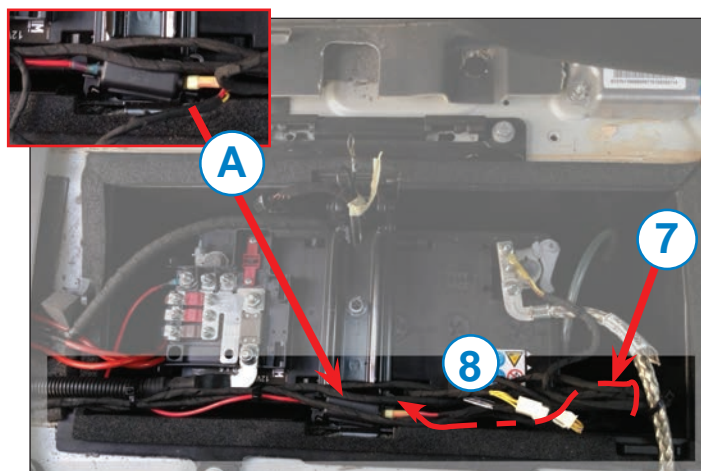

 **Use sufficient tie-wraps to secure the fuse block (A).**

 **Use sufficient tie-wraps to secure the wires.**

 **Ensure that tubes cannot be placed under tension or become damaged.**

- Route the red and yellow cables to the fuse box at front left.
- Route the white connector for the remote control through into the fuse box.
- Unscrew and remove the bolt.

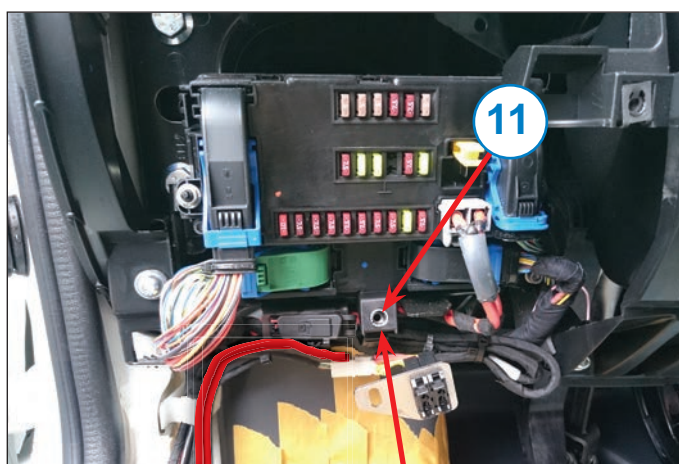

 **Use sufficient tie-wraps to secure the wires.**

- Connect the two red wires to the fuse block to which the **F1 40A** fuse will later be connected.
- Connect the two yellow wires to the fuse block to which the **F2 7.5A** fuse will later be connected.
- Fit the fuse blocks to the fuse block support.
- Install the fuse block in the fuse box using the supplied distance bushes.

1 x bolt	M6 x 30
1 x washer	M6
1 x distance bush nylon	Ø15 x 11



- Do not fit the fuses yet.

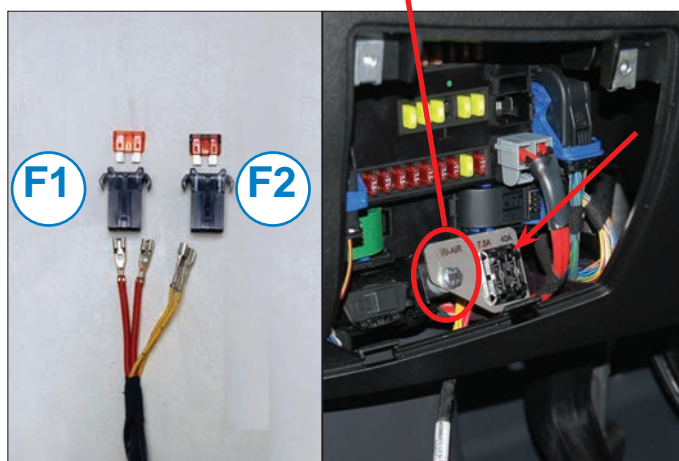

- 17. Connect the red wire to the connection marked on the positive battery terminal. (+).

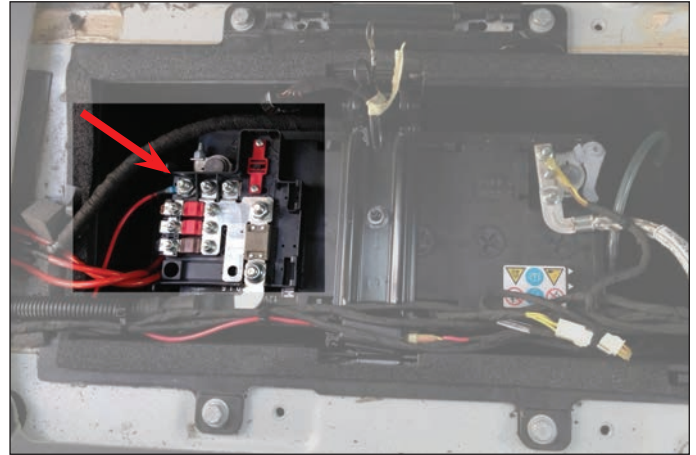

 ***If there are 2 batteries, always use the original starter battery and not the accessories battery.***

- 18. Connect the yellow and brown wires to the negative battery terminal (-)

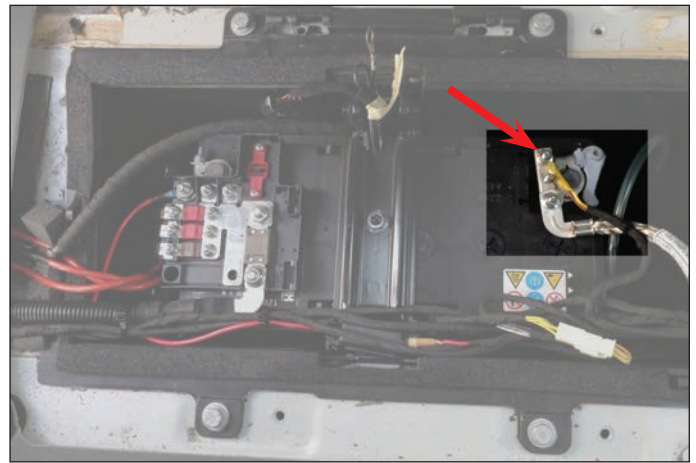

- 19. Connect the supply cable to the white connector.

 ***The vehicle must be fitted with factory option: 081***
If not, go to item 20.
If it is not, go to section 9 and 10.

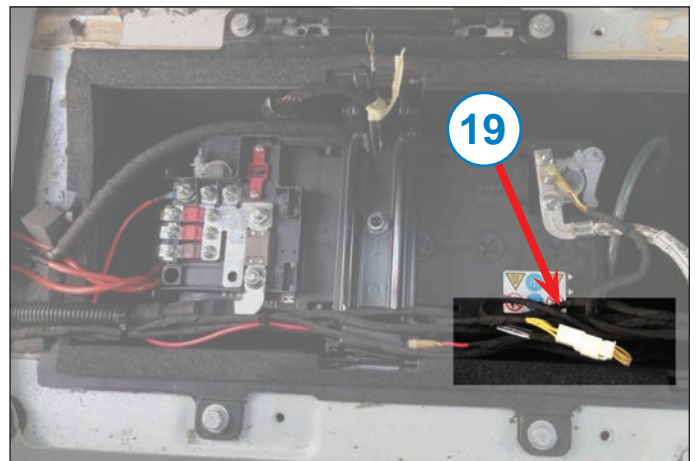

- 20. Route the supply cable under the trim to the right-hand side of the vehicle.

- 21. Connect the yellow wire to position 3 of the white connectors supplied for option 081.
- 22. Connect the red wire to position 13 of the white connectors supplied for option 081.

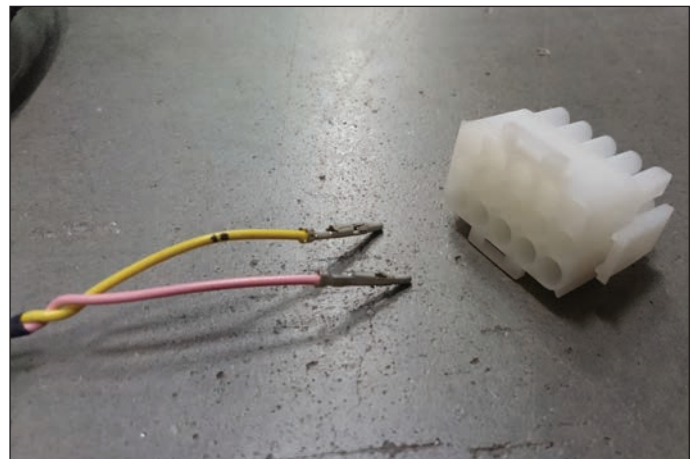

23. The white connector for option **081** is in the B-pillar on the right.
24. Connect the white connector supplied for option **081** to the white connector.

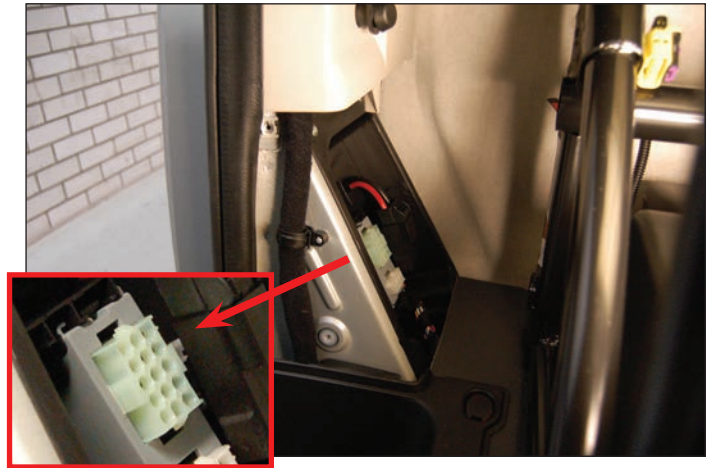

4.3 Handbrake signal

1. Remove the handbrake cover.
2. Route the white wire of the supply cable to the handbrake.



3. Remove the connector from the handbrake.
4. Fit the connector of the supply cable to the handbrake.
5. Fit the connector of the handbrake to the supply cable.

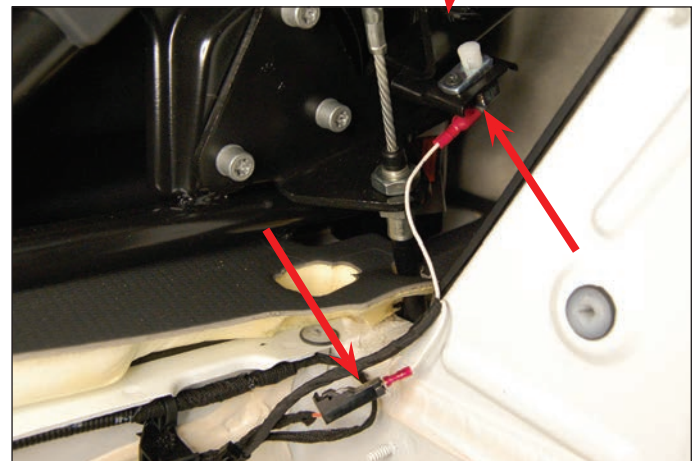

6. Route the wire as shown.
7. Fit the handbrake cover.

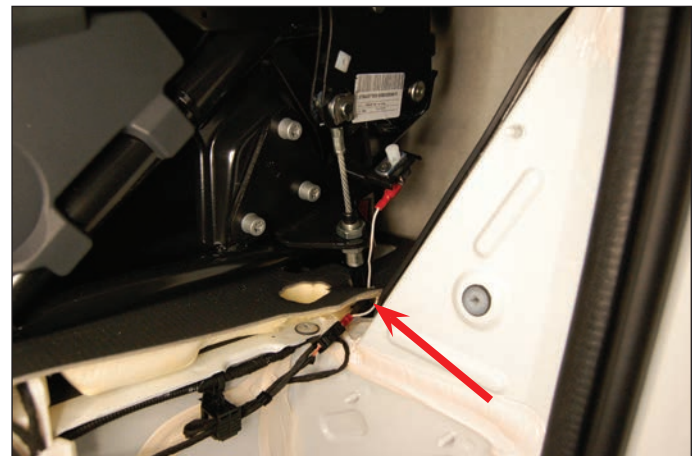

4.4 Remote control

1. Connect the remote control wire to the VB wiring harness that has already been installed in the fuse box.
2. Using a cable tie, fit the connector for the remote control to the fuse box.
3. Identify a suitable location to install the remote control.
VB-Airsuspension recommends the position shown in the photograph.



Ensure that the remote control is never in the way of the airbags.



4. Place the remote control in the holder.
5. Ensure the connector is not under tension. Secure the end of the wire with a tie-wrap.
6. Refit the interior components removed earlier.



5. Fitting the air suspension kit for the rear axle

5.1 Preparations

Option **A** is the standard fitting of the height sensor.

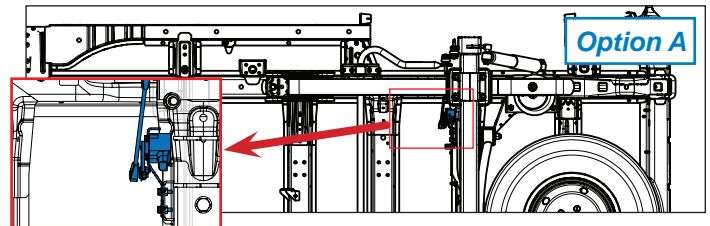

- If:
- $X < 80$ mm → option **B**.
 - $Y < 145$ mm → option **B**.

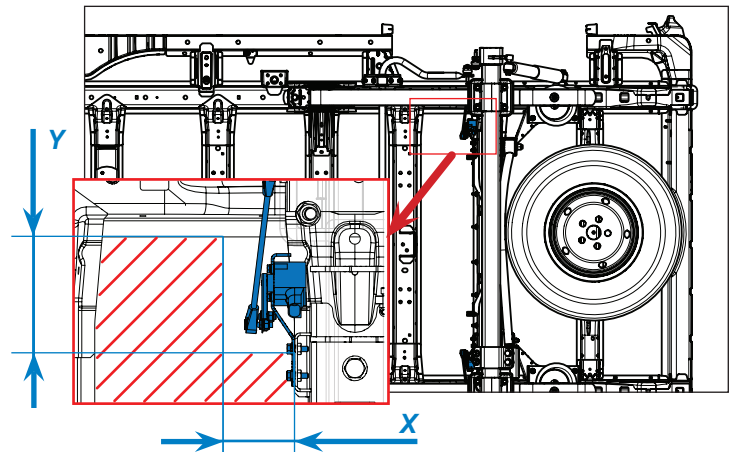

Option **B** is the alternative fitting of the height sensor. Use the kit with article number 105 209 02 68 (if supplied).

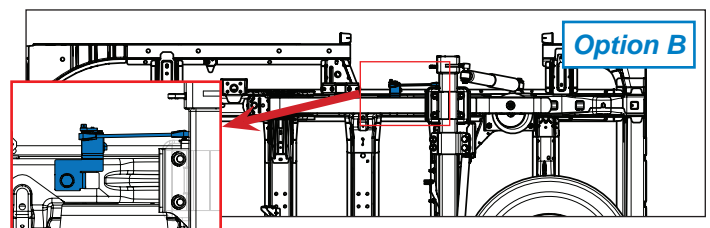

1. Support the vehicle and the axle properly.
2. Remove the spare wheel.
3. Remove the shock absorbers.



The nuts and bolts will be re-used.

4. Remove the bump stops.
5. Remove the handbrake cable bracket.
6. Remove the U-bolts.
The nuts and U-bolts will not be re-used.

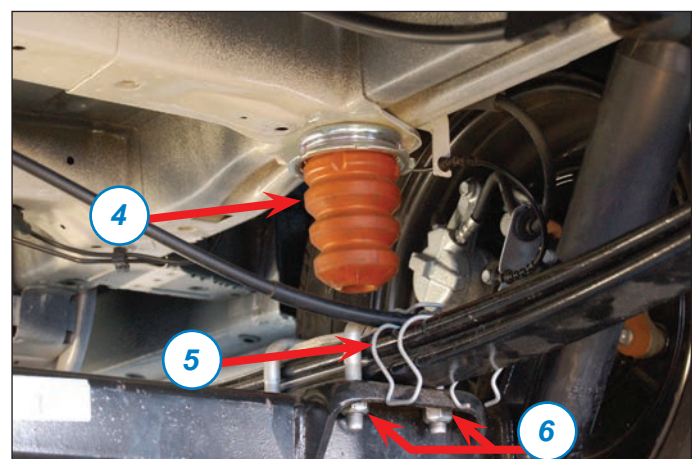

To stop the rear axle moving, it is advisable to replace one leaf spring first. Then replace the other leaf spring.

- Remove the topmost bolt from the spring shackle.



Lower the rear axle slightly to make this easier.

- Lower the axle.
- Remove the bolt from the front leaf-spring bracket. The bolts will be re-used.
- Remove the leaf springs.



Protect the exposed surface with an anti-corrosion agent. Use spray wax or a protective coating for this purpose.

- Remove the spring carrier arm bushes to the rearmost spring arm carrier. These parts are now no longer necessary for this vehicle.

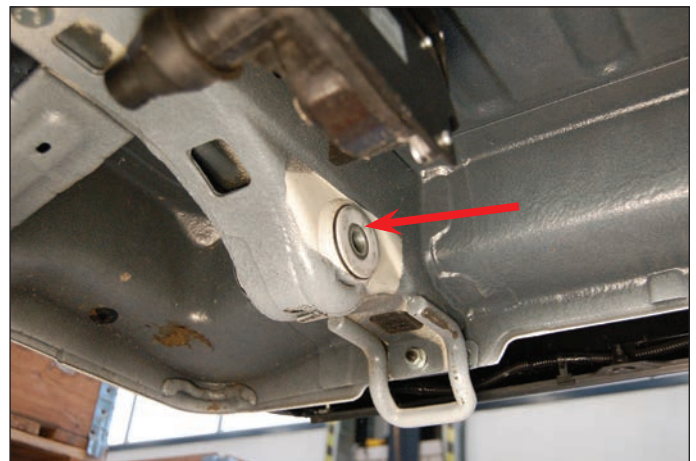

5.2 Main spring

- Fit the Panhard rod ball-joint to the top left leaf-spring seat bracket.
- Secure the castellated nut with a split pin.

1 x castellated nut	M14 x 1.5
1 x washer	M14
1 x split pin	M14



75-85 Nm
Then tighten until split pin fits.

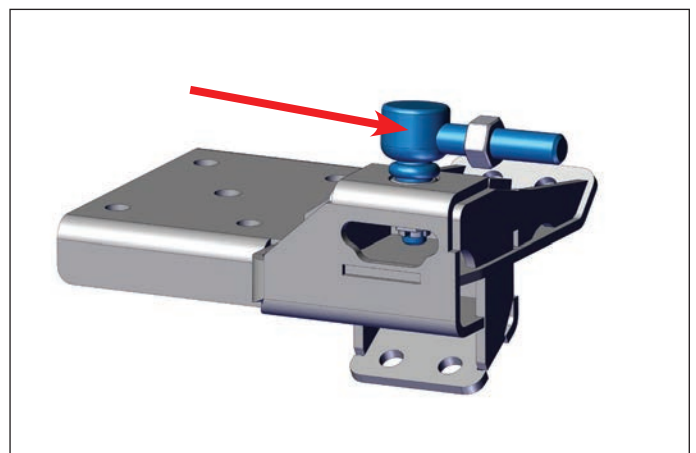

3. Fit the distance plate to the leaf-spring seat bracket.
Observe the spring-seat-dependent positions.

C: narrow spring seat
D: wide spring seat

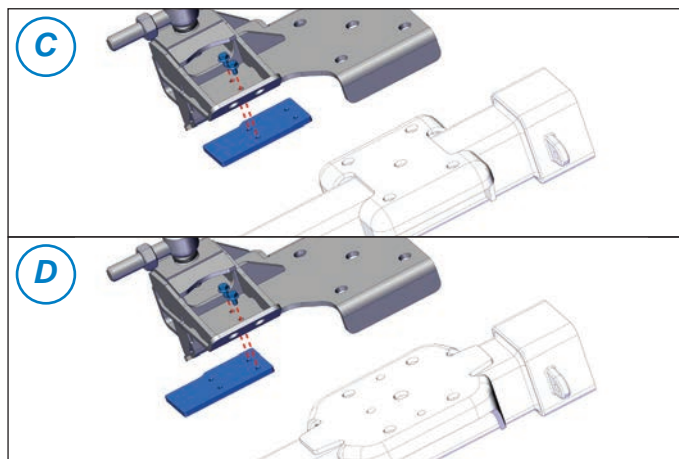

2 x flange bolt **M6 x 10**



8 Nm

4. Fit the ball-joints to the ball-joint brackets.

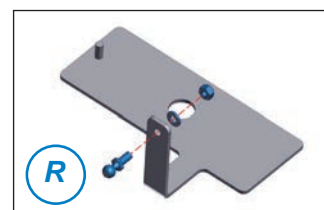
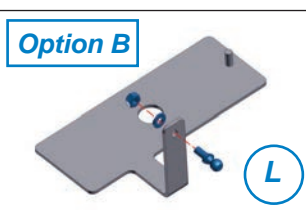
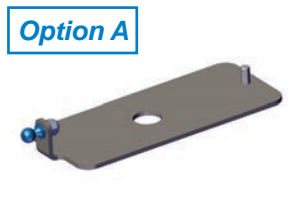

2 x ball joint **M6**
2 x washer **M6**
2 x steel lock nut **M6**



8 Nm

5. Fit the upper left leaf-spring seat bracket with the Panhard rod ball-joint to the spring seats on the left-hand side of the vehicle.

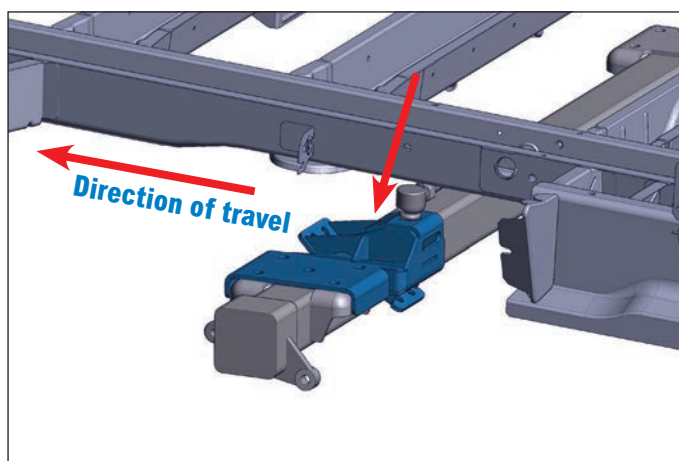

6. Place the main spring on the spring seat.
7. Fit the main spring in the frontmost leaf-spring bracket.
Use the original bolt and a new nut.
**** Do not tighten the nuts yet. Tighten them once the vehicle is at the ride height.**

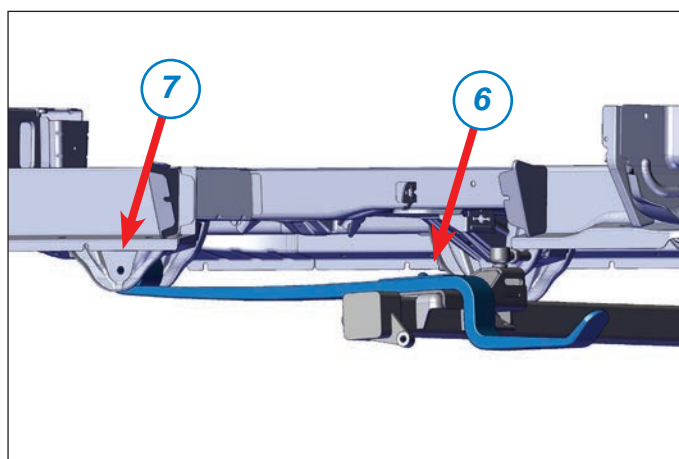

1 x original bolt
1 x steel lock nut** **M16**



185 Nm

8. Place the ball-joint bracket on the main spring.
9. The ball-joint bracket ball-joints must point:
 - towards the front of the vehicle (*option A*).
 - towards the outside of the vehicle (*option B*).

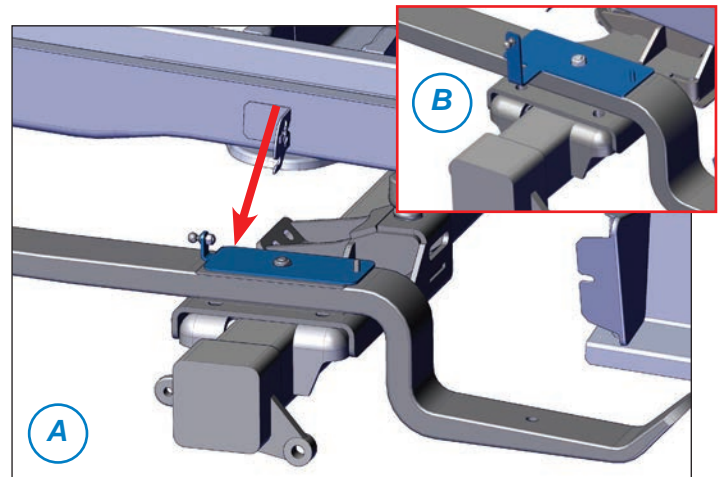

10. Place the original spring clamping plates on the main spring.
11. Fit the new U-bolts.

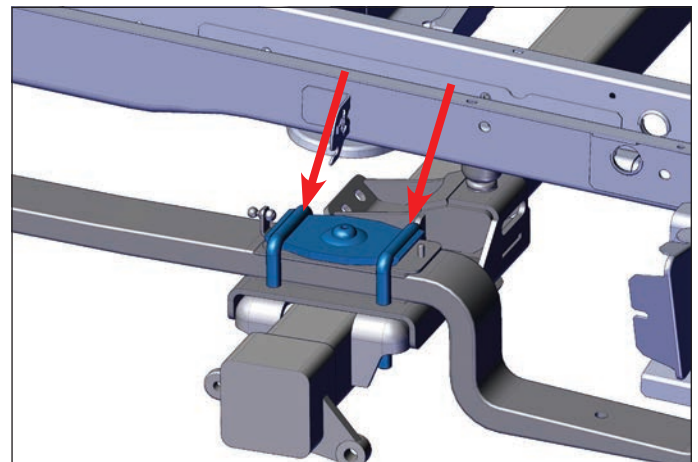

2 x U-bolt	M14
-------------------	------------

12. Fit the bottom left leaf-spring seat bracket under the spring seat.
13. Fit the new leaf-spring U-bolt nuts.
 - ** Do not tighten the nuts yet. Tighten them once the vehicle is at the ride height.**

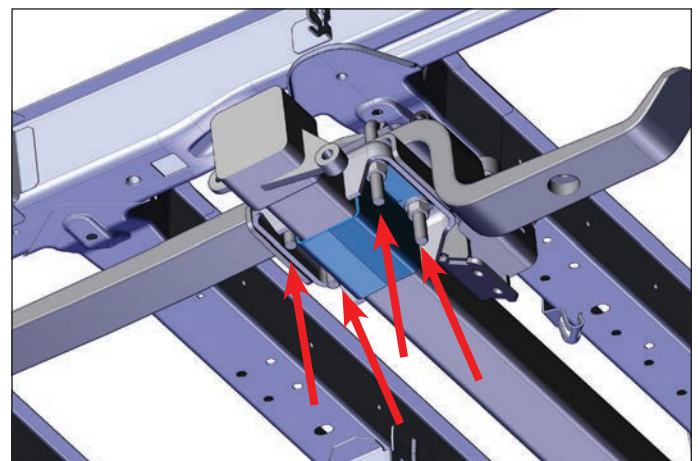

4 x flange nut **	M14
8 x original washer	M14



130 Nm

14. Fit the upper right leaf-spring seat bracket.

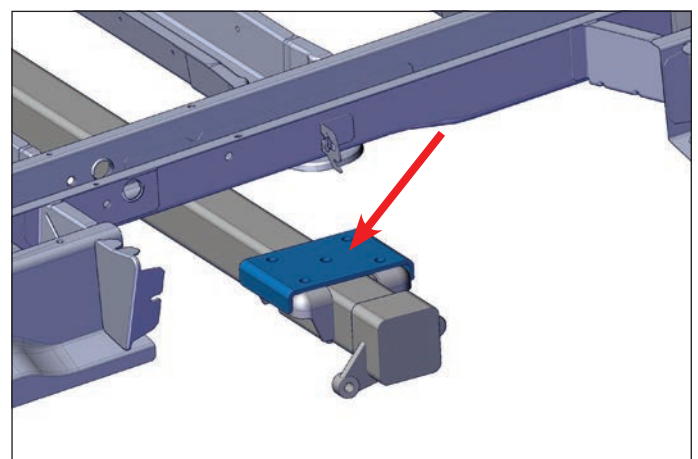

15. Place the right hand main spring on the right hand spring seat.
16. Fit the main spring in the frontmost leaf-spring bracket.
Use the original bolt and a new nut.
**** Do not tighten the nuts yet. Tighten them once the vehicle is at the ride height.**

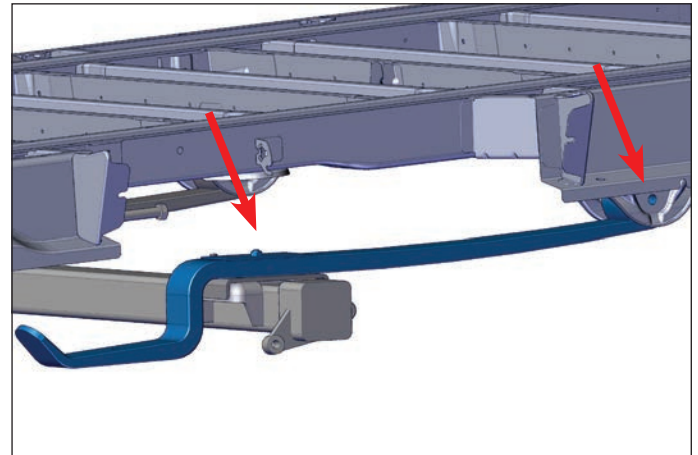

1 x original bolt	
1 x steel lock nut**	M16
	185 Nm

17. Place the ball-joint bracket on the main spring.
18. The ball-joint bracket ball-joints must point:
 - towards the front of the vehicle (**option A**).
 - towards the outside of the vehicle (**option B**).

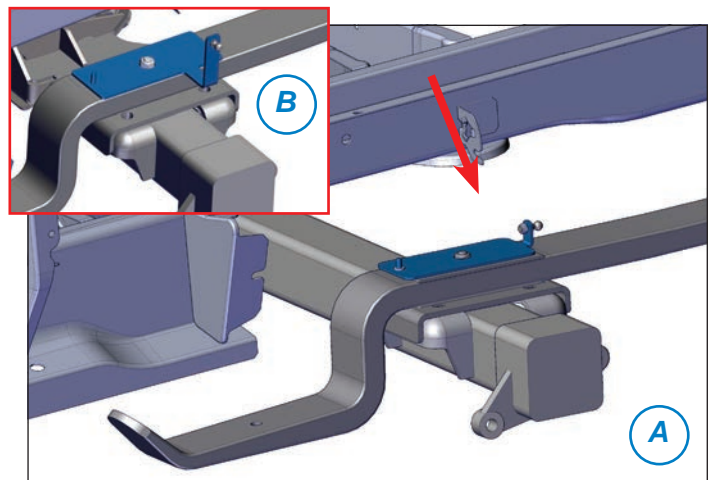

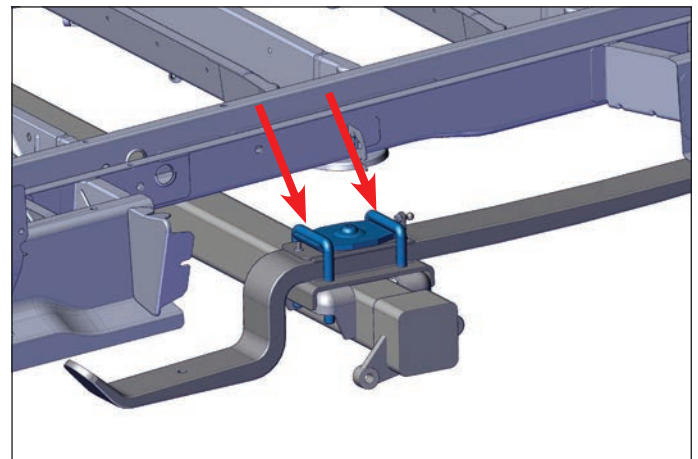

19. Place the original spring clamping plates on the main spring.
20. Fit the new U-bolts.

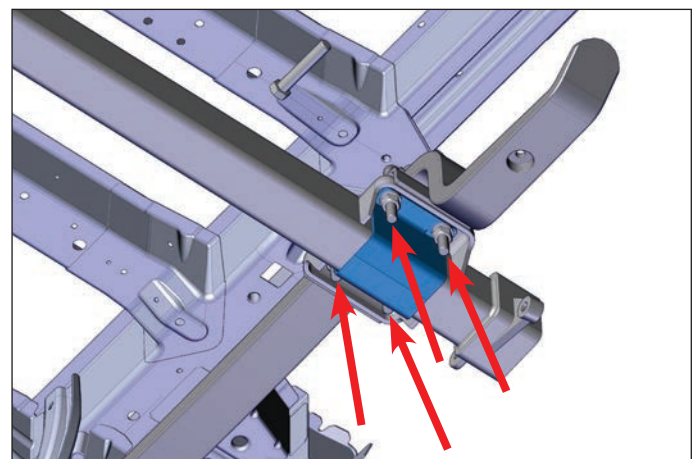

2 x U-bolt	M14
-------------------	------------

21. Fit the bottom-right leaf-spring seat bracket under the spring seat.
22. Fit the new leaf-spring U-bolt nuts.
**** Do not tighten the nuts yet. Tighten them once the vehicle is at the ride height.**



4 x flange nut **	M14
8 x original washer	M14
	130 Nm

23. Fit the handbrake cables to the ball-joint brackets.



- | | |
|-----------------------|-----------------|
| 2 x pipe clamp | Ø20 - 15 |
| 2 x washer | M6 |
| 2 x lock nut | M6 |



8 Nm

5.3 Upper cross beam

- Fit the upper crossbeam to the chassis.
Fit only the left-hand bolt.
**** Do not tighten the bolt yet.**

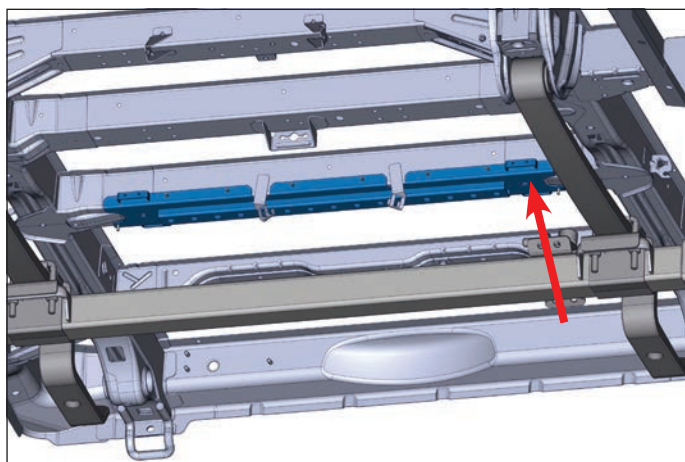

- | | |
|-------------------|-----------------------|
| 1 x bolt** | M14 x 40 x 1.5 |
| 1 x washer | M14 |



160 Nm

- Fit the Panhard rod bracket to the upper cross beam.

- | | |
|-----------------------|-----------------------|
| 1 x bolt** (E) | M14 x 40 x 1.5 |
| 1 x washer | M14 |



160 Nm

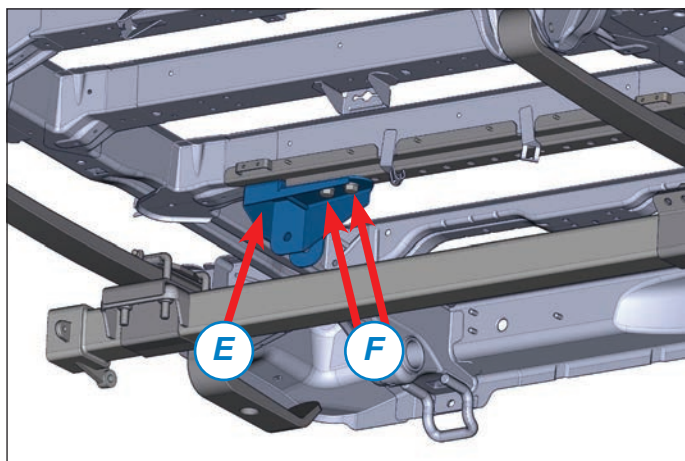

- | | |
|-----------------------|-----------------|
| 2 x bolt** (F) | M14 x 20 |
| 2 x washer | M14 |



130 Nm

- Fit the handbrake cable bracket to the upper cross beam.

- | | |
|-------------------|----------------|
| 2 x bolt | M8 x 20 |
| 2 x washer | M8 |



20 Nm

- Fit the handbrake cables to the handbrake cable bracket.

- | | |
|-----------------------|-----------------|
| 2 x pipe clamp | Ø20 - 15 |
| 2 x bolt | M6 x 20 |
| 4 x washer | M6 |
| 2 x lock nut | M6 |



8 Nm

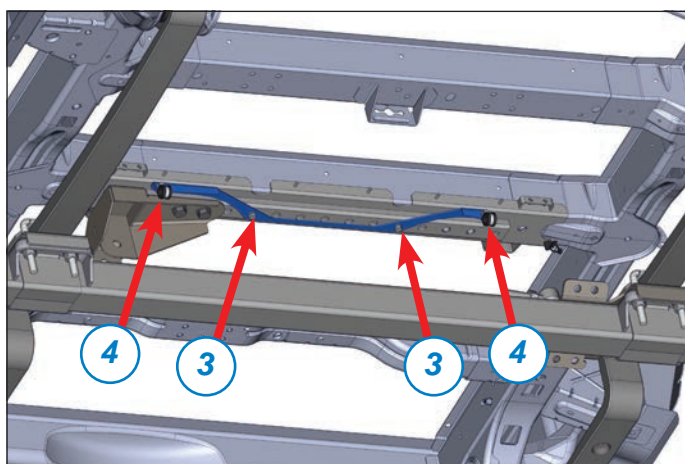

5.4 Panhard rod

1. Fit the lower clamp plate to the top-left spring seat.

4 x bolt	M14 x 35
8 x washer	M14
4 x lock nut	M14



140 Nm

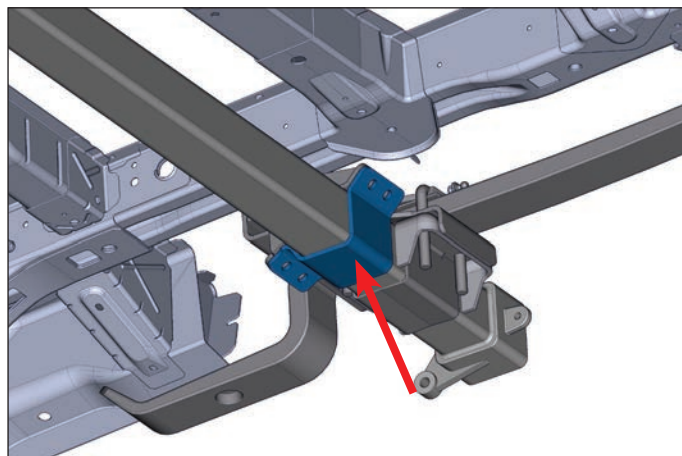

2. Lower the vehicle onto the calibration supports.



Go to section 2 for details of the correct calibration supports for this kit.

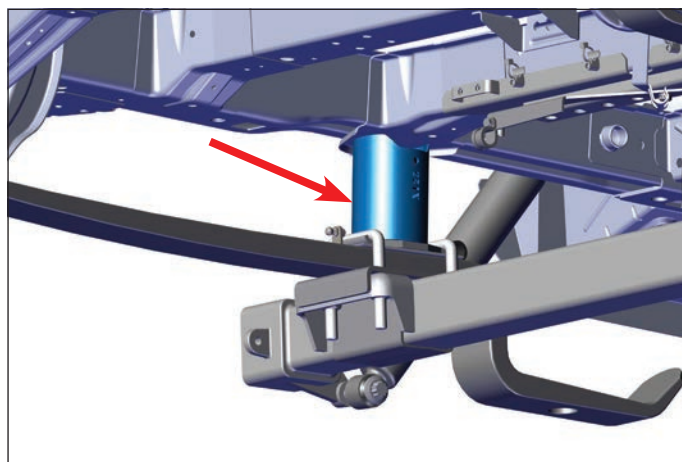

3. Secure the bolt from sections 5.2 and 5.3.

4. Screw the Panhard rod onto the ball joint.
 - ** **Do not tighten the nut yet.**
 - Use the curved panhard rod with the spare wheel set.
 - Use the straight panhard rod without the spare wheel set.



Apply grease to the thread.

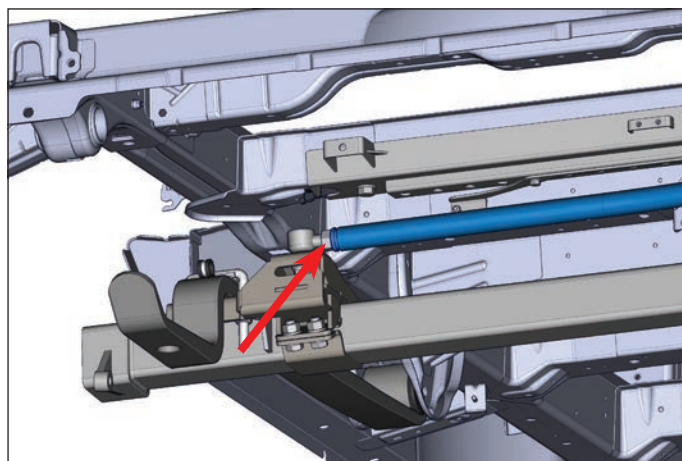

5. Measure the distance (**A**) between the chassis and rim edge on the left-hand side.
6. Measure the distance (**B**) between the chassis and rim edge on the right-hand side.
7. If there is a difference larger than 2 mm between the left and right measurements, correct it by pressing the chassis to one side relative to the rear axle.
8. Measure the distance (**A**) and (**B**).
9. If the difference is > 2 mm, adjust!
If the difference is < 2 mm, continue!
10. Turn the Panhard rod on the ball head until the bolt of the Panhard rod bracket fits.

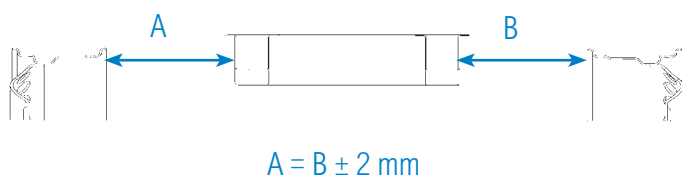

When making adjustments: 1 turn is equivalent to 1.5 mm of movement.

11. Fit the curved Panhard rod to the Panhard rod bracket (with the spare wheel set option) (G).



Ensure the correct curvature of the Panhard rod. It must point forward.

- | | |
|--------------|----------|
| 1 x bolt | M16 x 90 |
| 2 x washer | M16 |
| 1 x lock nut | M16 |



200 Nm

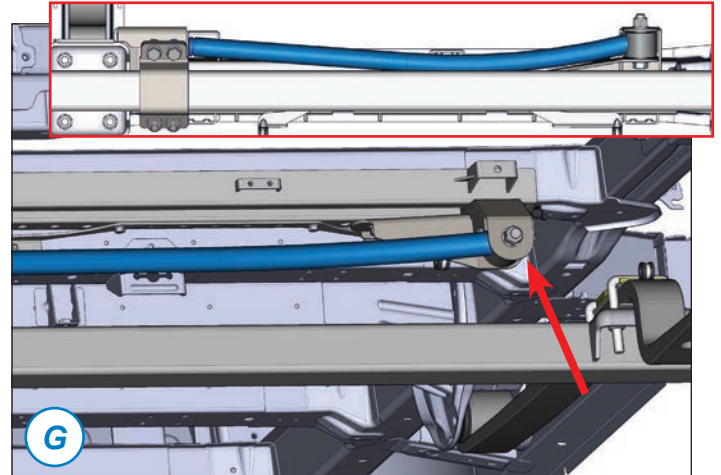

12. Fit the straight Panhard rod to the Panhard rod bracket (without the spare wheel set option) (H).

- | | |
|--------------|----------|
| 1 x bolt | M16 x 90 |
| 2 x washer | M16 |
| 1 x lock nut | M16 |



200 Nm

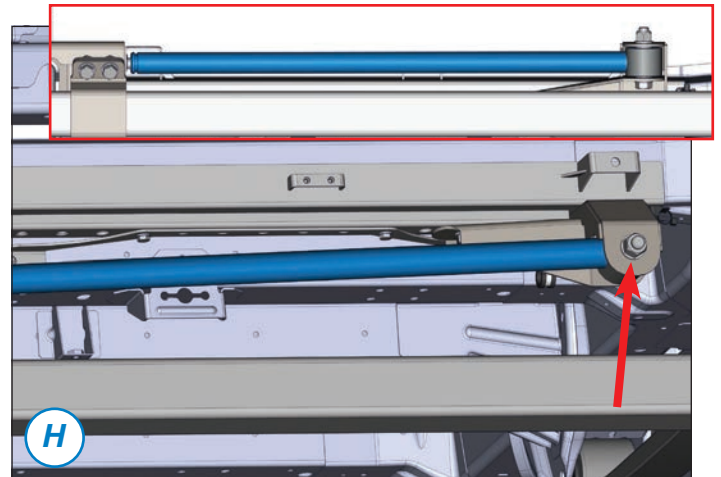

13. Ensure the ball joint is straight relative to the bracket when tightening the lock nut.
14. Tighten the lock nut.

nut supplied



65 Nm

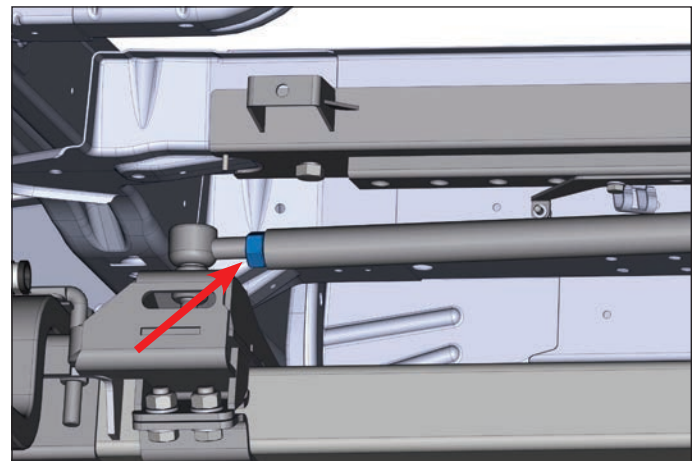

5.5 Bump stops

1. Mount the bump stop on the left-hand side using the shim.

1 x bolt	M10 x 50 x 1.25
1 x washer	M10



45 Nm

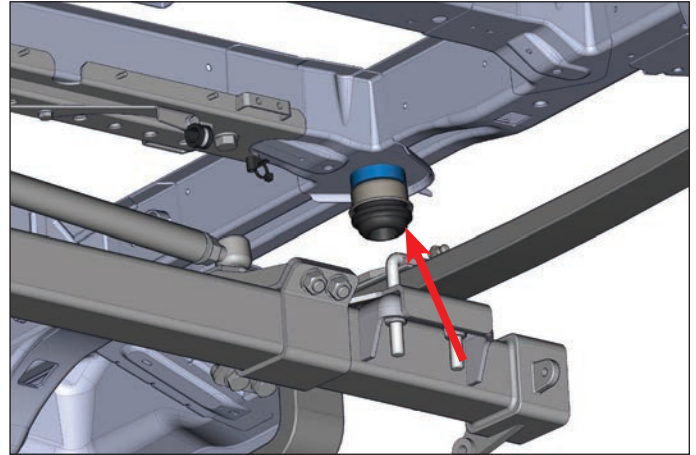

2. Mount the bump stop on the right-hand side with the shim.

1 x bolt	M10 x 50 x 1.25
1 x washer	M10



45 Nm

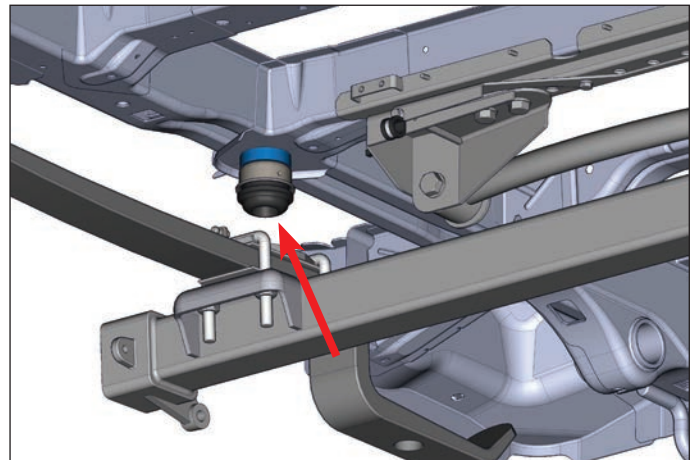

5.6 Spare wheel bracket

1. Fit the spare wheel bracket (if available).

2 x bolt	M6 x 20
2 x washer	M6



6 Nm

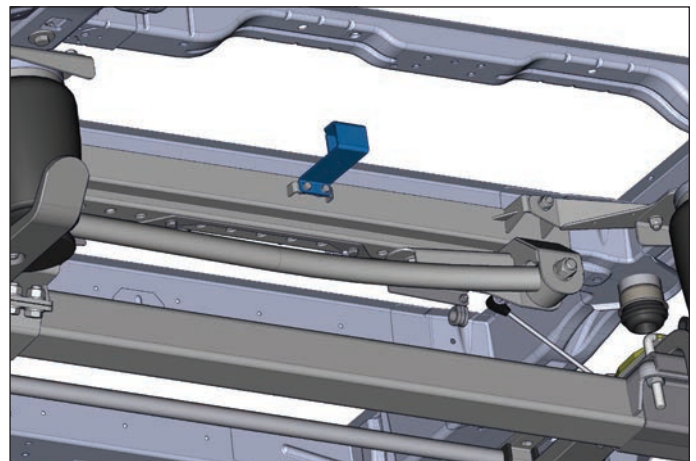

5.7 Air springs

1. Fit the upper bellows support to the mounting plate.
Do this on both sides.
Do not tighten the nuts and bolts yet.

4 x bolt	M10 x 25
8 x washer	M10
4 x lock nut	M10



65 Nm

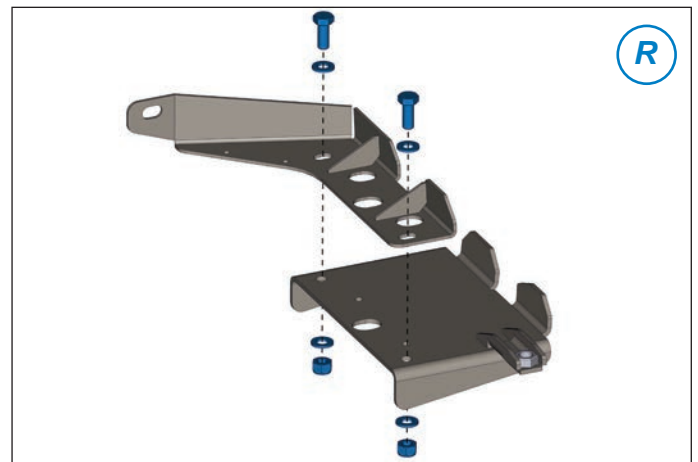
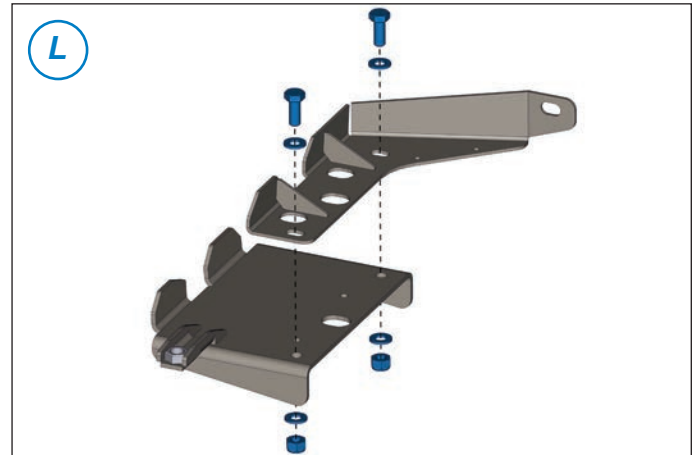

2. Fit the upper bellows supports to the chassis.

2 x bolt	M12 x 25
2 x washer	M12 x 37 x 3



60 Nm

3. Clamp mounting plate onto the chassis. Tighten the nuts and bolts from step 1.

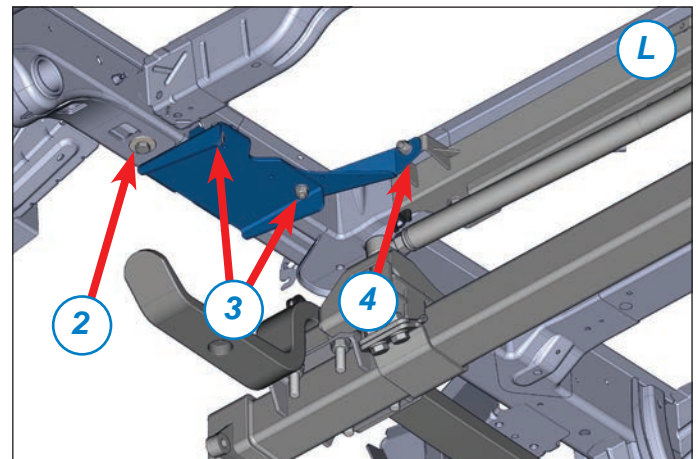

4. Fit the mounting plate to the upper cross beam.

2 x bolt	M10 x 25
4 x washer	M10
2 x lock nut	M10



65 Nm

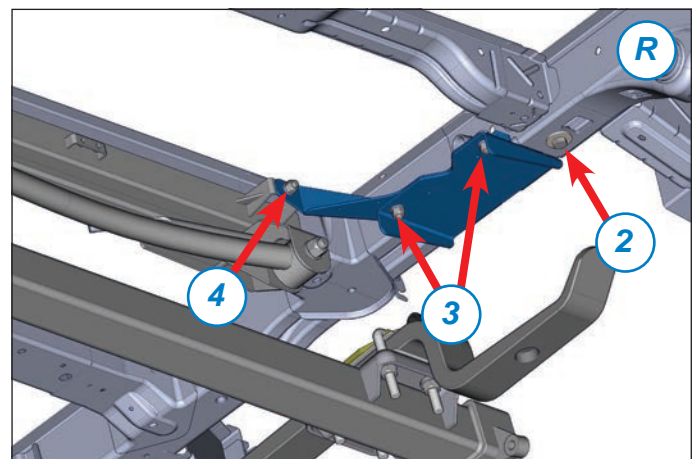

5. Slide the shim into the gap in the piston.
6. Fit the piston to the main spring.

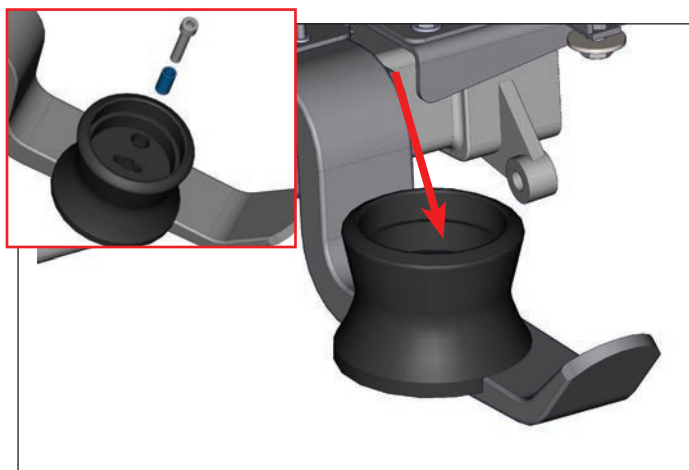

Fit the bolts from the top

2 x Allen screw	M10 x 50
2 x washer	M10
2 x lock nut	M10



35 Nm

7. Fit the air couplings to the air springs.



air coupling



3 Nm

8. Fit the air springs to the piston.

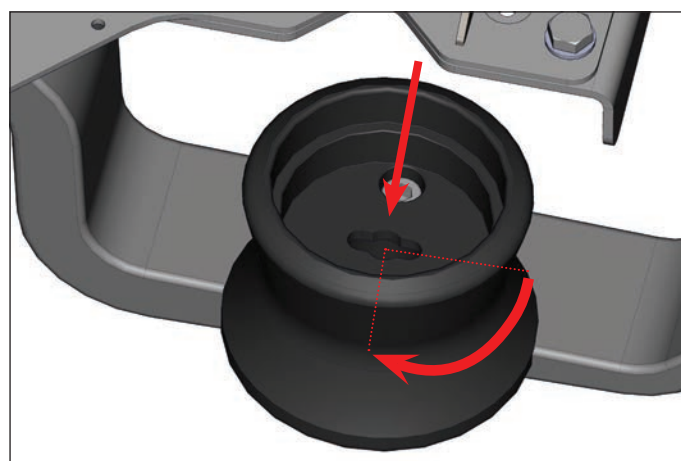

The air coupling must face towards the inside of the vehicle.



Rotate the air spring one quarter turn in the piston.

9. Fit the air springs to the upper bellows supports.

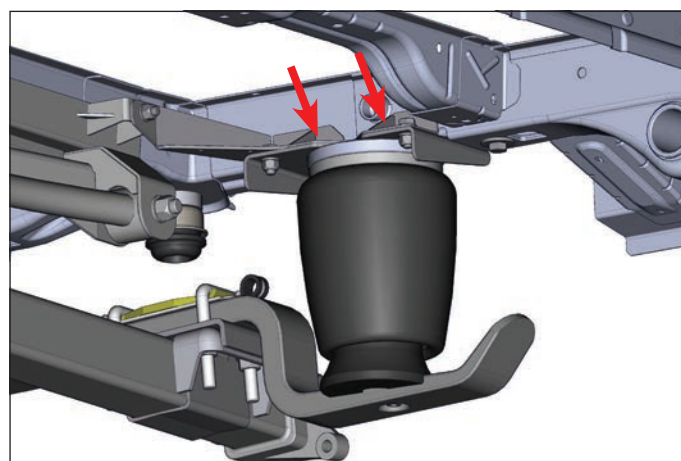

4 x flange bolt	M6 x 10
------------------------	----------------



8 Nm

5.8 Height sensors

5.8.1 Height sensors option A

1. Fit the height sensors to the height sensor brackets as shown in the figure.

4 x bolt	M5 x 10
4 x washer	M5



6 Nm

2. Fit the right height sensor bracket.
Always use Loctite locking agent.

2 x bolt	M6 x 20
2 x washer	M6



8 Nm

3. Fit the left height sensor bracket.
Always use Loctite locking agent.

2 x bolt	M6 x 20
2 x washer	M6



8 Nm

4. Check the length of the height sensor rods **210 mm** - measured centre to centre.
5. Mount the height sensor rods on the height sensors and ball joints.
6. Secure the height sensor rods by pushing in the clips.



The height sensor arms must point inwards.

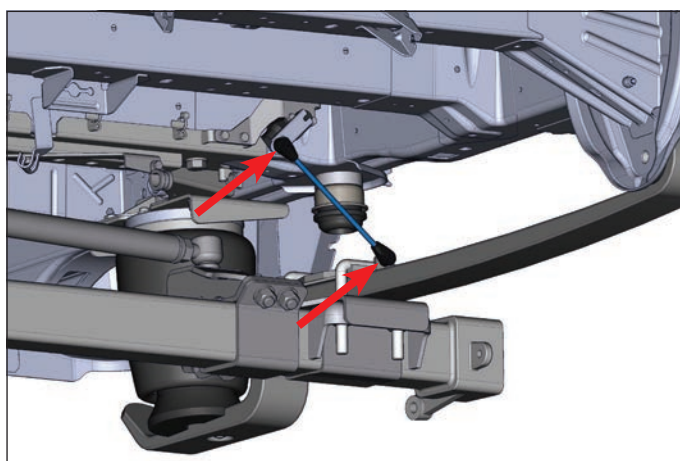
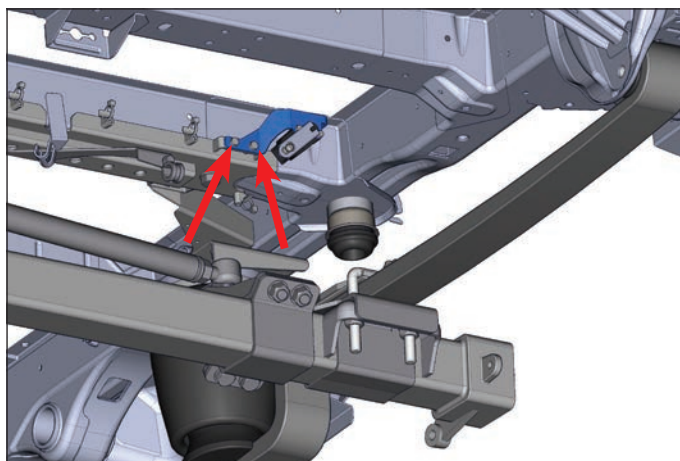
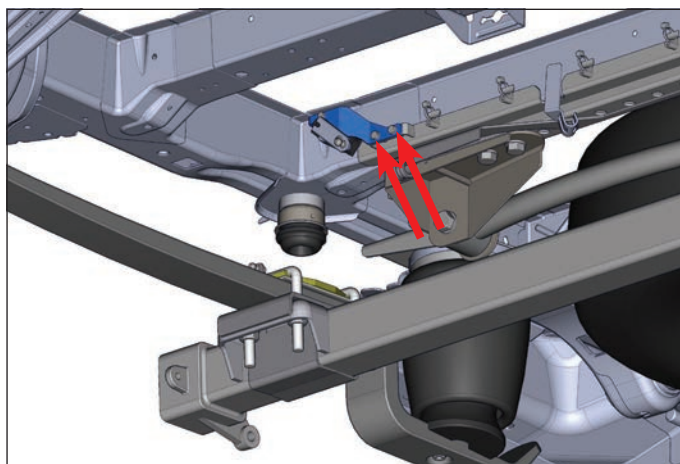
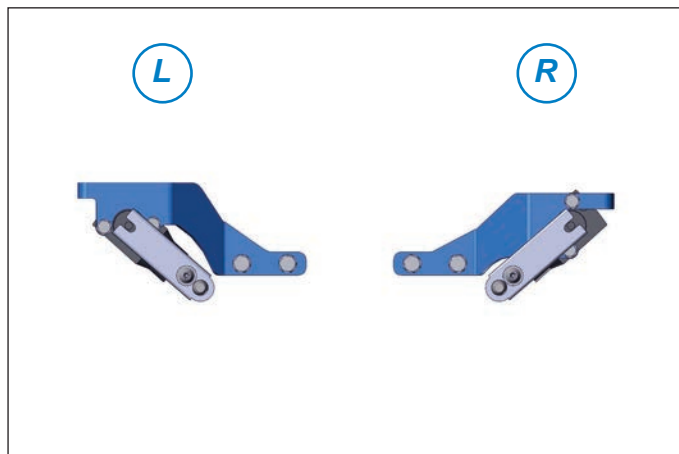

5.8.2 Height sensors option B

1. Fit the height sensors to the height sensor brackets as shown in the figure.

4 x bolt	M5 x 10
4 x washer	M5



6 Nm

2. Fit the right height sensor bracket.

1 x bolt	M14 x 40
1 x washer	M14



50 Nm

3. Fit the left height sensor bracket.

1 x bolt	M14 x 40
1 x washer	M14



50 Nm

4. Check the length of the height sensor rods **200 mm** - measured centre to centre.
5. Mount the height sensor rods on the height sensors and ball joints.
6. Secure the height sensor rods by pushing in the clips.



The height sensor arms must point forwards.

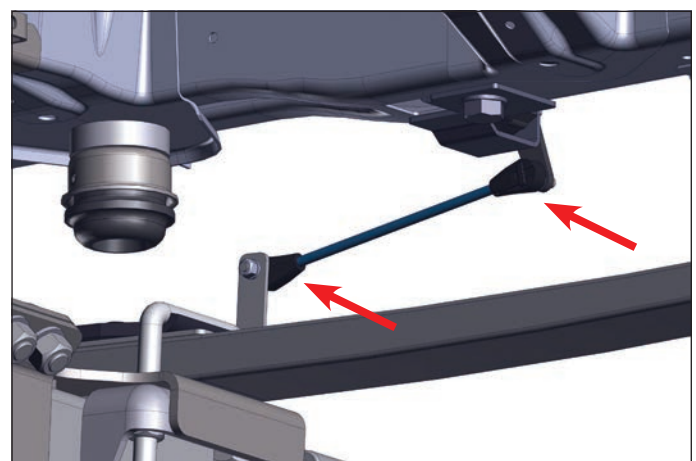
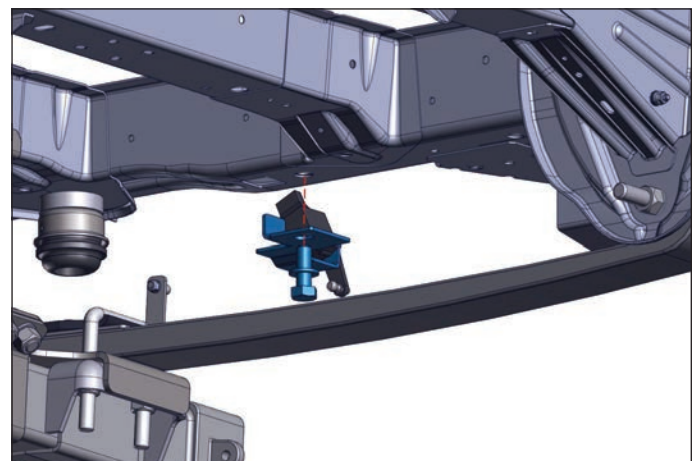
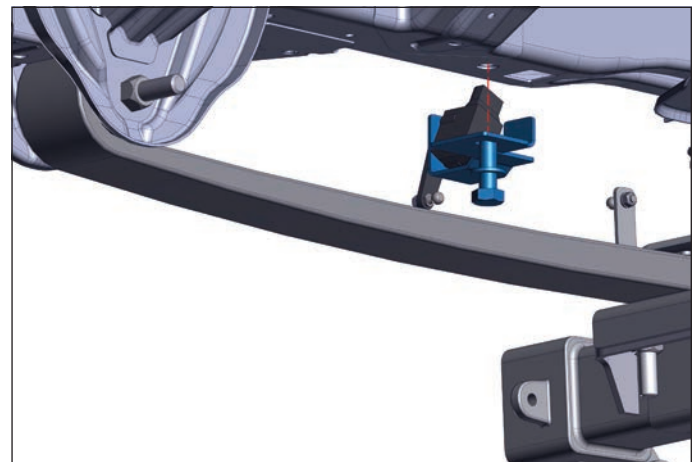
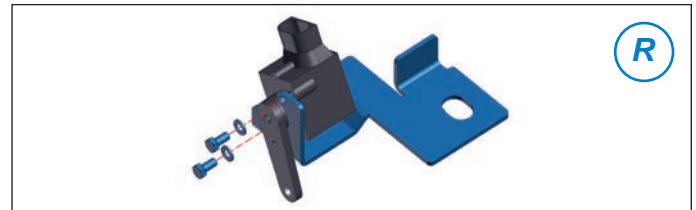
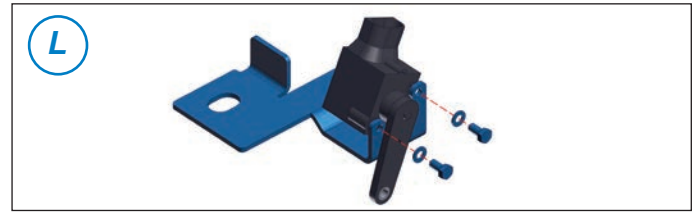

5.9 Shock absorbers

1. Bleed the shock absorbers before being fitted.
2. Clamp the shock absorbers vertically in a bench vice.



The wide end of the shock absorbers is viewed as the top.

3. Gently push the top down and then slowly pull it up again.

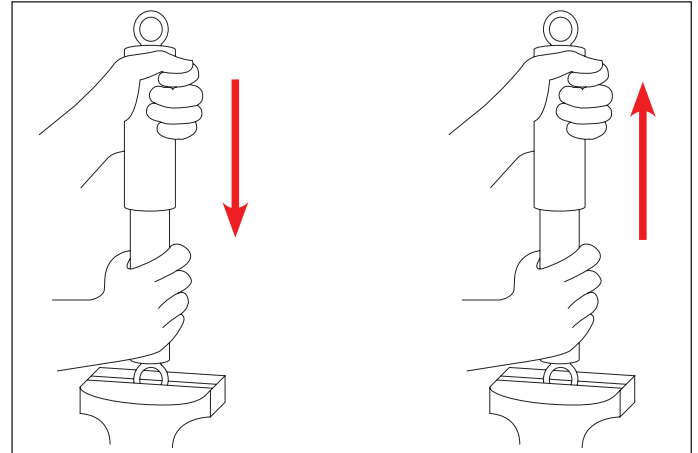

4. A slurping noise may be heard at the end of the stroke; this indicates the presence of air.
5. Continue this pumping action until the slurping noise is no longer heard.



Always hold the shock absorber with the top pointing up. If this doesn't happen, air will enter the shock absorber again.

6. Fit the new shock absorbers.



Use screw thread locking when tightening the bolt.

Original fasteners



145 Nm

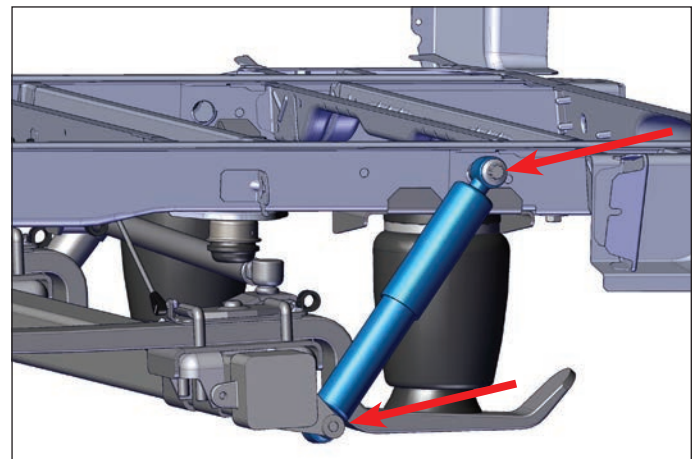

5.10 Air tank

1. Remove both exhaust brackets.
2. Pull the head shield with the exhaust brackets downwards slightly so that the air tank mounting bracket can be placed on the chassis.

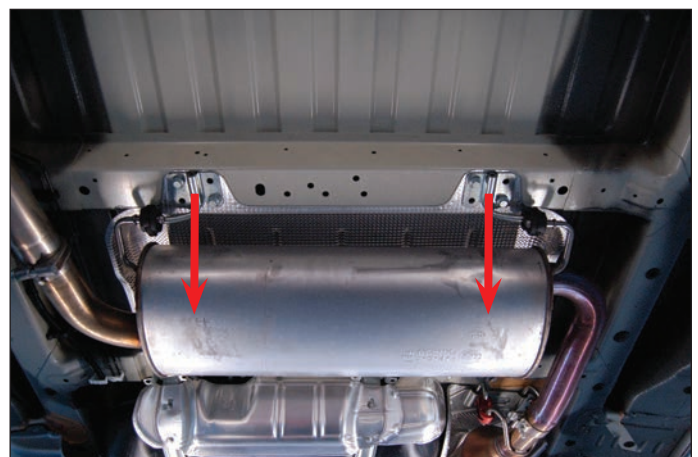

- Mount the air tank mounting bracket in the position indicated.

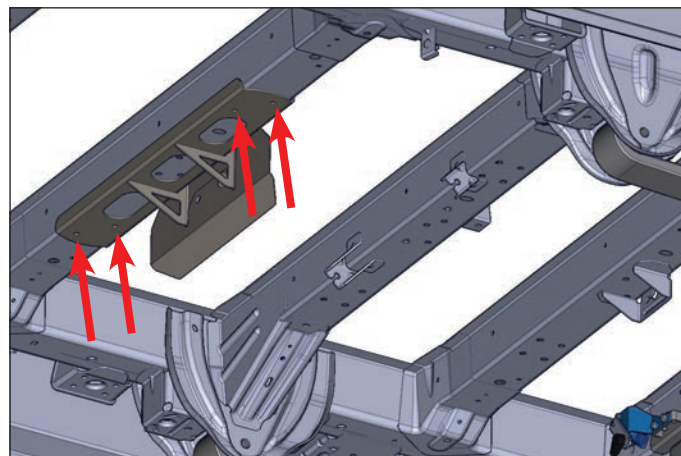

Fit the air tank mounting bracket between the chassis and heat shield.

Original fasteners



30 Nm

- Fit the blank plugs in the air tank.
Fit the air couplings to the left-hand side of the air tank.

3 x blank plug
1 x hex bushing M22 > M22 1/8"



30 Nm

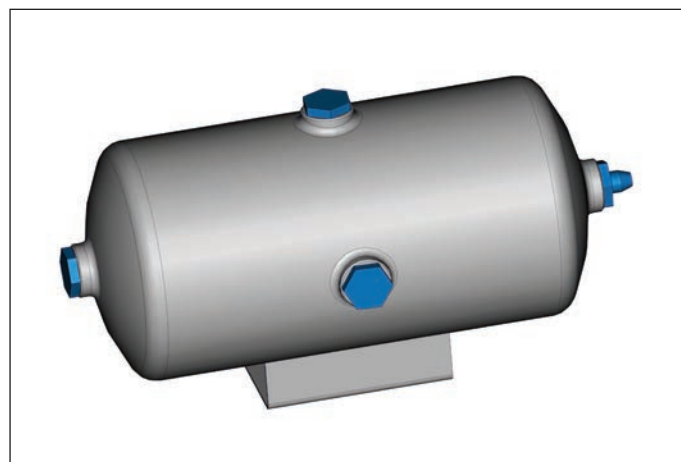

- Fit the air coupling in the air tank.

air coupling



3 Nm

- Fit the air tank to the air tank bracket.

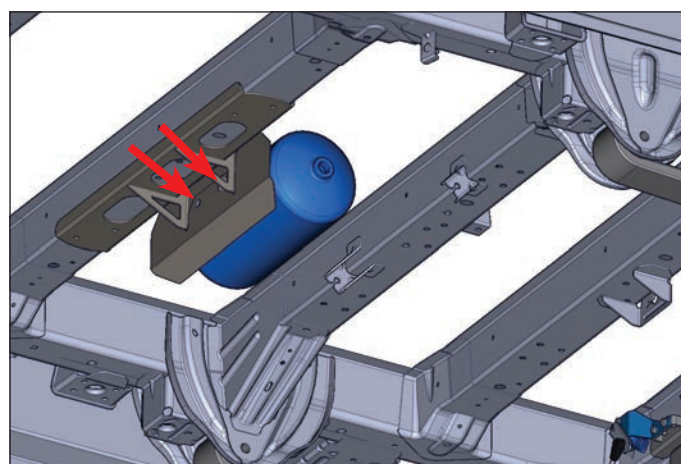

2 x bolt M12 x 25
2 x washer M12



93 Nm

- Fit the yellow air tube to the air tank.
- Route the yellow air tube to the compressor box.



Use sufficient tie-wraps to secure the air tubes and wires!



The yellow air tube of the air tank must not exceed 2 m in length.

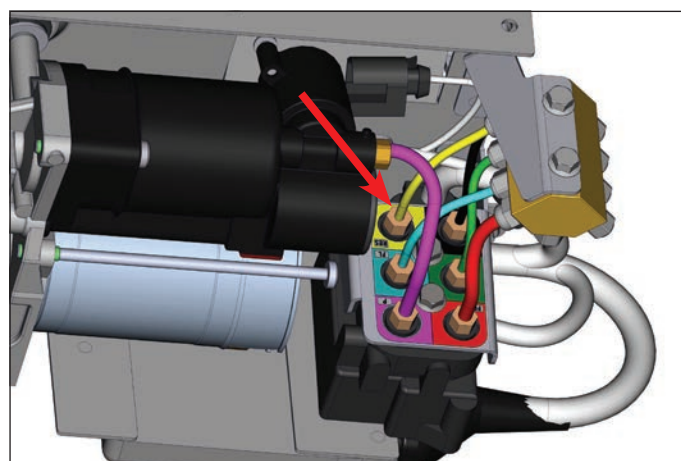

- Fit the yellow air tube to the valve block.
- Ensure that the colour markings match.

5.11 Air tubes and height sensor cables

1. Route the black air tube with the height sensor cable along the upper cross-beam to the left-hand side of the chassis.

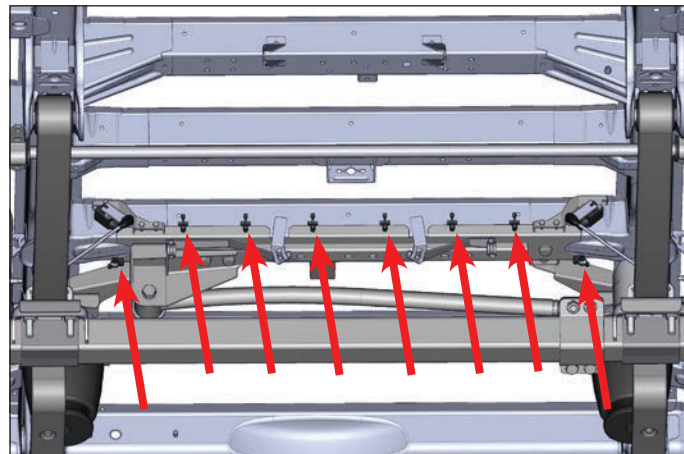

2. Connect the cables to the height sensors. The illustration is for indicative purposes only for showing the height sensor cable mounting bracket.

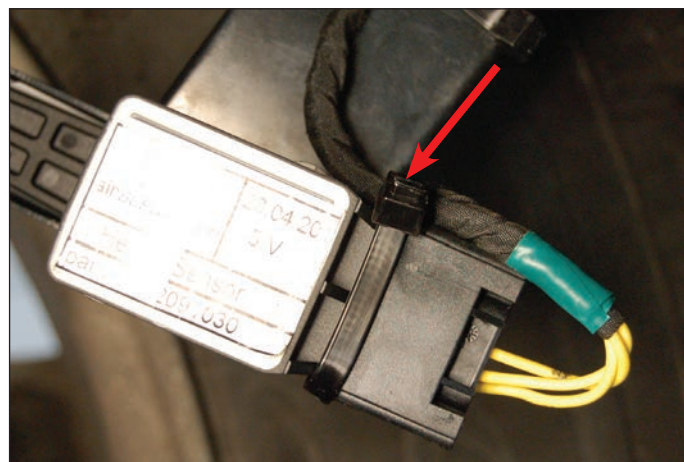

3. Route the air tubes along the left-hand side of the chassis to the compressor box.

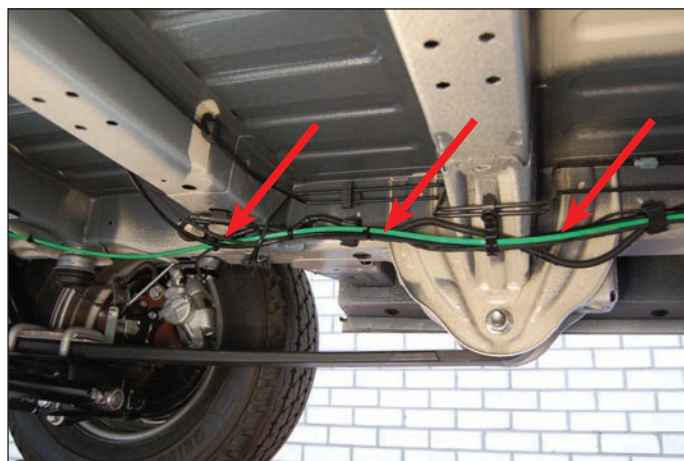

Never attach air tubes, wires or other parts to the vehicle's brake lines.



Use sufficient tie-wraps to secure the air tubes and wires!

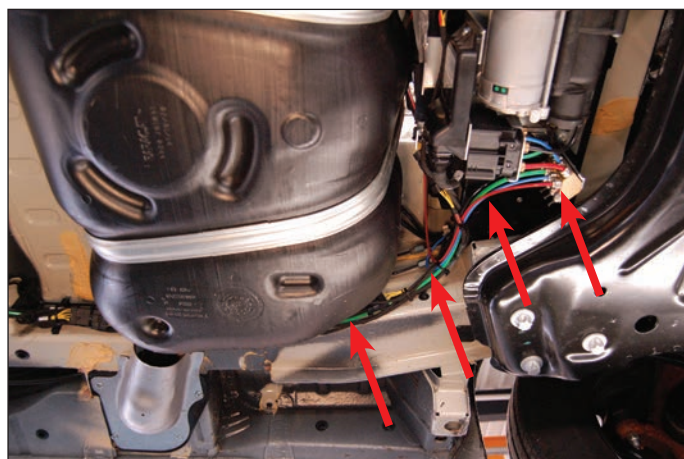

4. Fit the **green** air tube to the air coupling on the junction block on the outside of the compressor box.
5. Fit the **black** air tube to the junction block air coupling on the outside of the compressor box.
6. Ensure that the colour markings match.
7. If no emergency valve set is available, seal the unused air couplings with the supplied end plugs.
8. *If kit 105 16 01 4XX for the front and rear axle has been fitted, continue from section 6.*

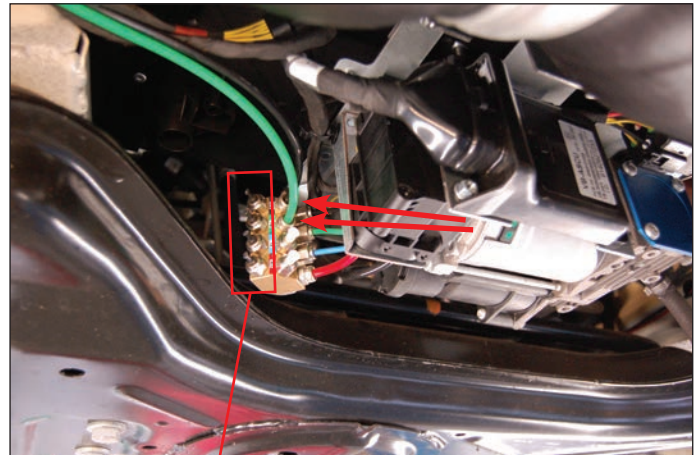

Air couplings for emergency valve kit (optional)

9. Fit the cover to the compressor box.

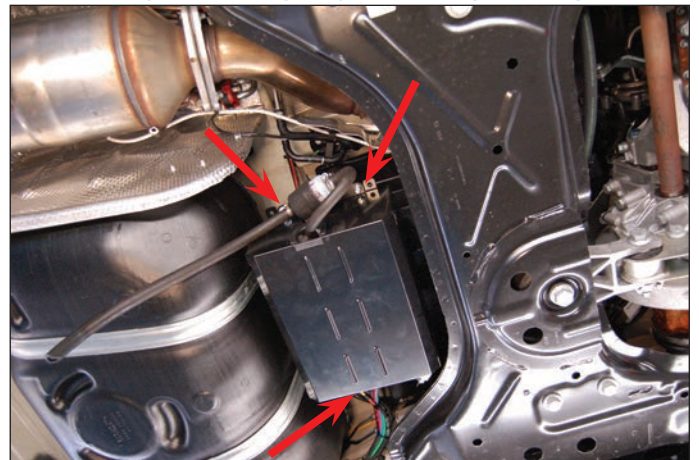

3 x flange lock nut

M6



8 Nm

10. Fit the suction filter to the inlet line.

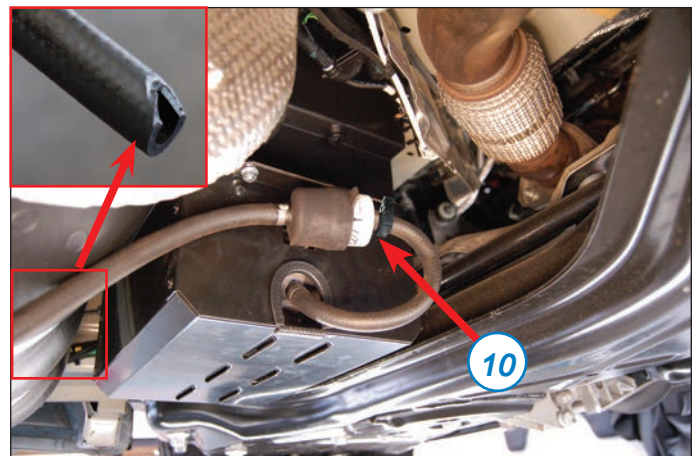

11. Fit the rubber grommet to the chassis.
12. Route the inlet line with the rubber grommet into the chassis.

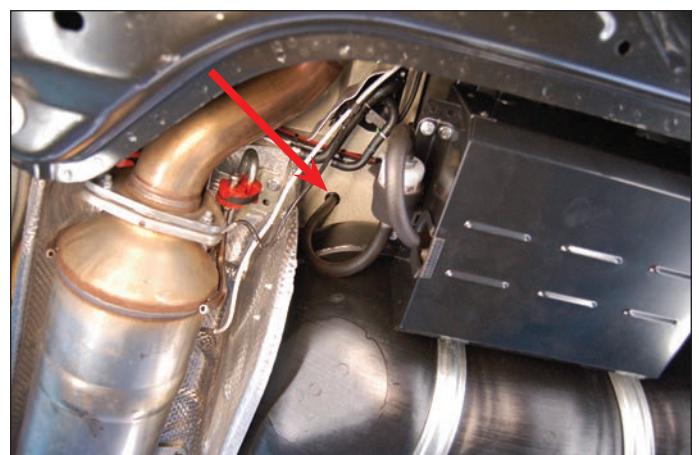

5.12 Warranty stickers

1. Fit the spare wheel.
2. Affix the supplied warranty stickers **A + B** to the B-pillar on the passenger's side.



3. Affix sticker **B** to the left spring plate.

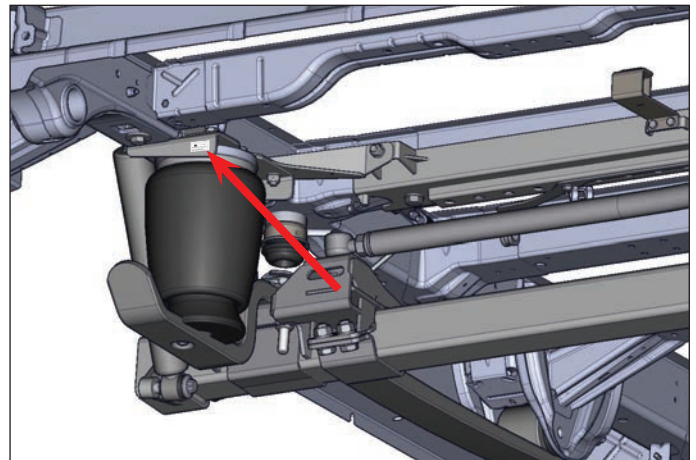

A

B

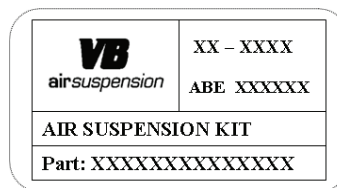

If kit 105 18 07 2XX for the rear axle has been fitted, continue from chapter 7.

If kit 105 18 07 4XX for the front and rear axle has been fitted, continue from chapter 6.

6. Fitting the air suspension kit to the front axle

6.1 Preparations

1. Support the vehicle and the axle properly.
2. Remove the wheels.



3. Remove the plastic cover.
4. Do this on both sides.
5. Remove the fuse box.



6. Remove the insulating material.
7. Undo the bolts, leave 1 bolt loosely in place (a few turns).

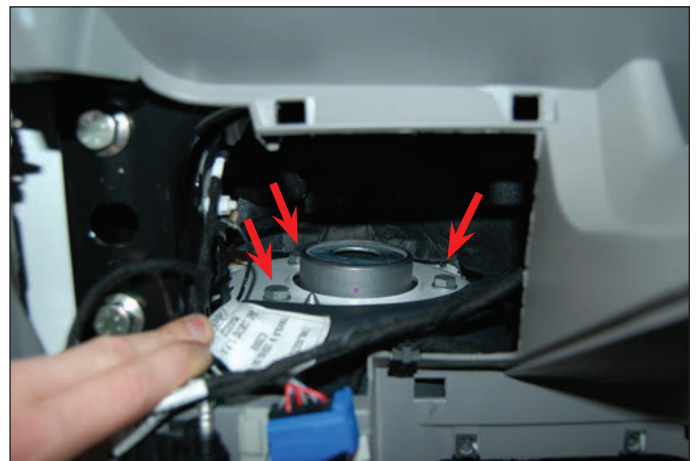

8. Take the tubes off the bracket.

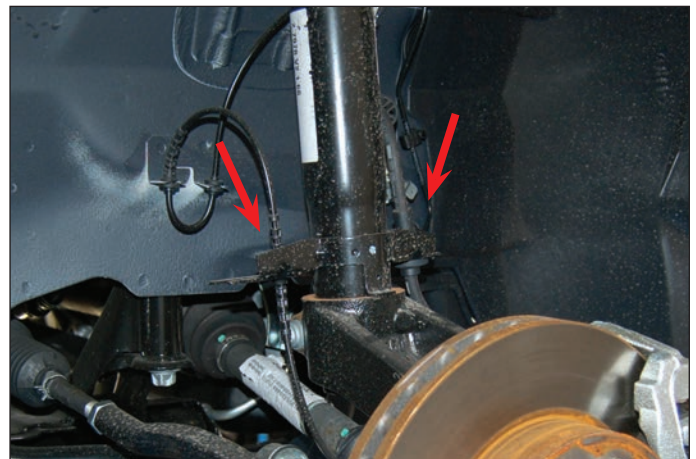

- Undo the bolts.
The nuts and bolts will be re-used.



- Unscrew the stabiliser arm.

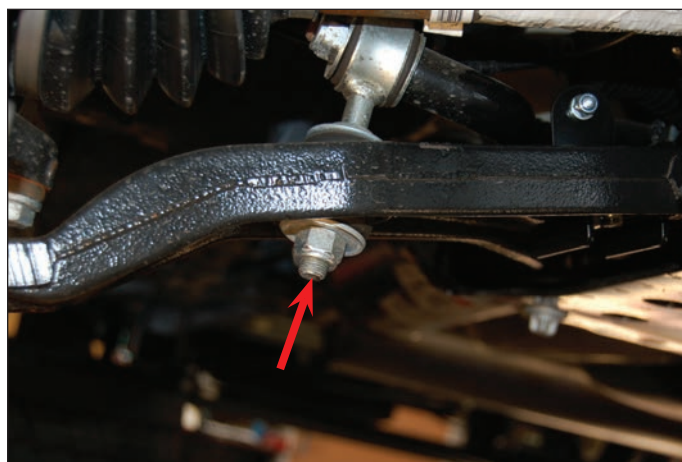

- Use a tyre lever on the inside of the stub axle to remove the suspension strut.
- Remove the suspension strut.

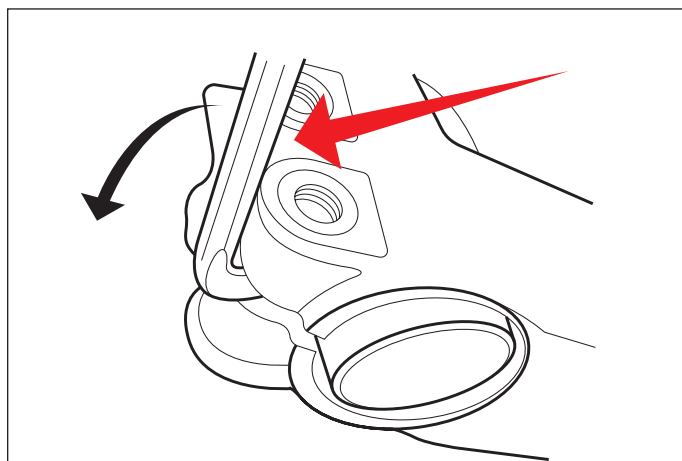

	Ensure the drive shaft is not pulled out of the gearbox.
	Ensure that tubes cannot be placed under tension or become damaged.

6.2 Suspension strut

- Place the new suspension strut in the stub axle.
- Ensure that the lip abuts the stub axle.
- Fit the bolt.
**** Do not tighten the bolts yet. Tighten them once the vehicle is at the ride height.**

2 x original bolt**	
2 x original nut	
	X250: 120 Nm X290: 170 Nm
	The colour markings indicate which part is for the left and which for the right. See 'Fitting instructions'.

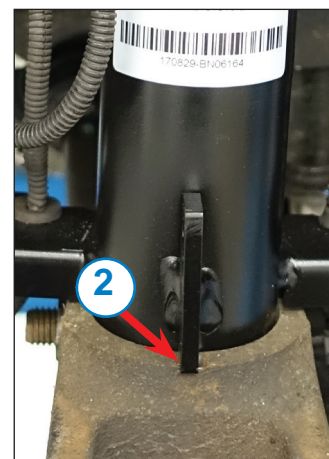



4. Check that the locating pins drop into the holes.
5. Fit the top of the suspension strut.
**** Do not tighten the bolts yet. Tighten them once the vehicle is at the ride height.**

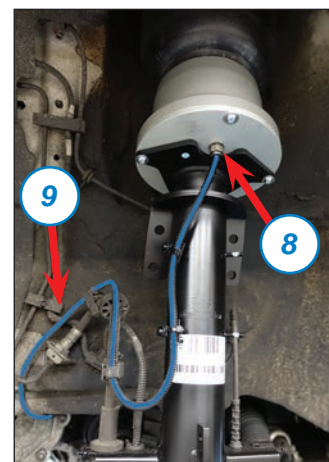

6 x bolt**	M10 x 30 x 1.25
6 x washer	M10
	60 Nm

6. Fit all tubes and wires to the suspension strut.
7. Connect the **red** air tube to the right air spring.
8. Connect the **blue** air tube to the left air spring.
9. Lay the air tube along the route indicated to the compressor box.
10. Secure the air tube with the special clips.



	Push the tube at least 80 mm into the air coupling.
---	--

6.3 Height sensors

1. Fit the height sensors to the height sensor brackets as shown in the figure.
2. Be careful to check whether it is the left or right bracket.

4 x bolt	M5 x 10
4 x washer	M5
	6 Nm

	The colour markings indicate which part is for the left and which for the right. See 'Fitting instructions'.
---	---

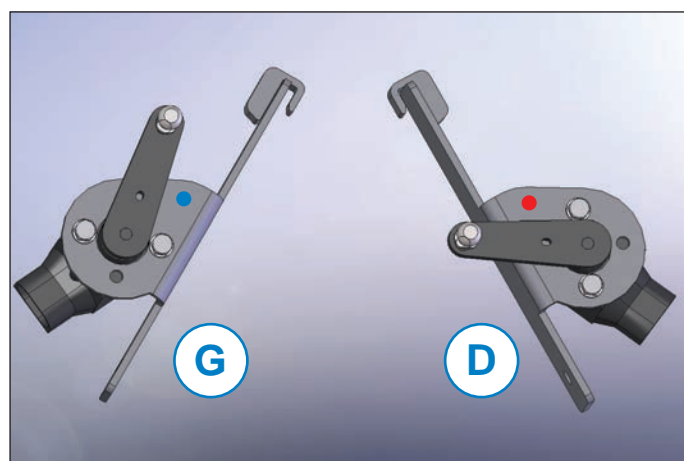

3. Mount the height sensor brackets in the position indicated.

2 x bolt	M6 x 50
4 x washer	M6
2 x lock nut	M6
	8 Nm

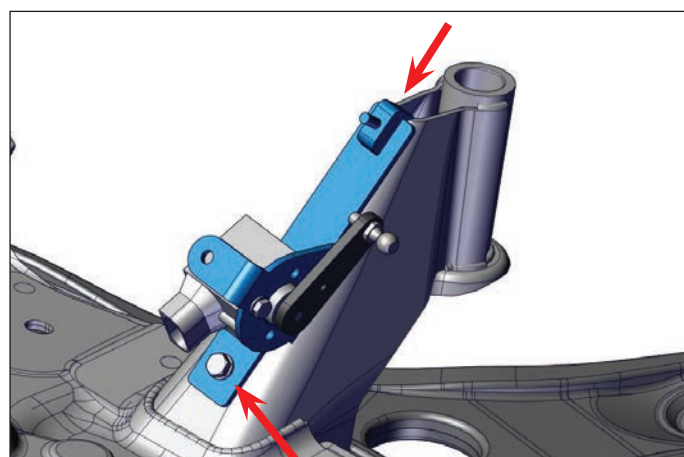

4. Fit the ball-joints to the ball-joint brackets.

- | | |
|-----------------------|-----------|
| 2 x ball joint | M6 |
| 2 x washer | M6 |
| 2 x lock nut | M6 |



8 Nm



The colour markings indicate which part is for the left and which for the right. See 'Fitting instructions'.



5. If the vehicle model year is up to 2014, continue from point 7.
6. If the vehicle model year is from 2014 onwards, continue from point 11.



7. Place the ball-joint brackets on the suspension arm.

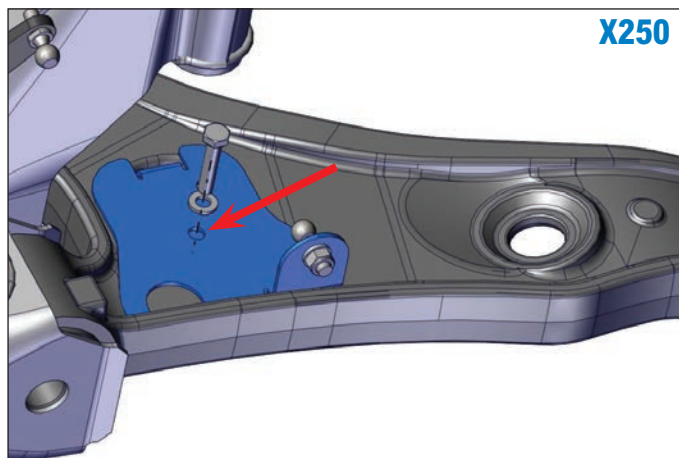

8. Fit the plate on the underside.
9. Tighten the bolts.
10. Continue from point 14.

- | | |
|---------------------|----------------|
| 2 x bolt | M6 x 30 |
| 4 x washer | M6 |
| 2 x lock nut | M6 |



8 Nm

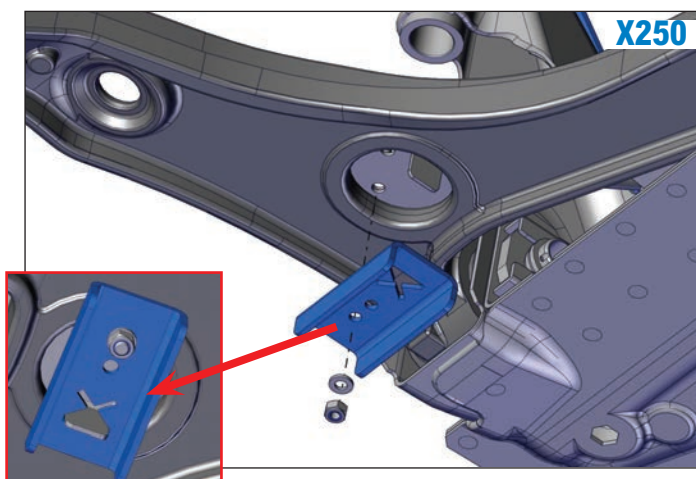

11. Place the ball-joint brackets on the suspension arm.

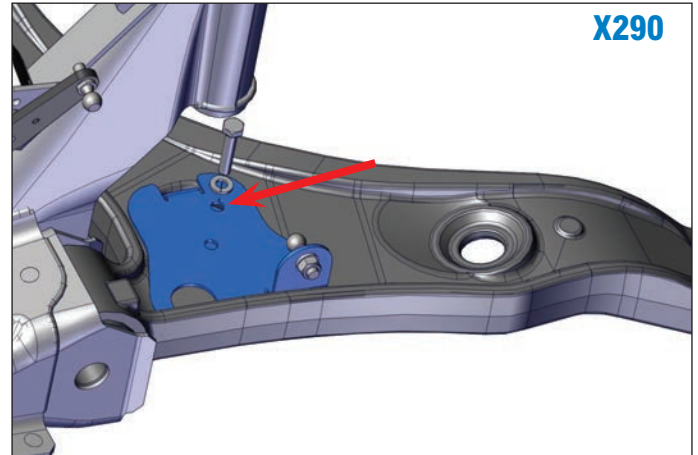

12. Fit the plate on the underside. Use spacer bush (A).

13. Tighten the bolts.

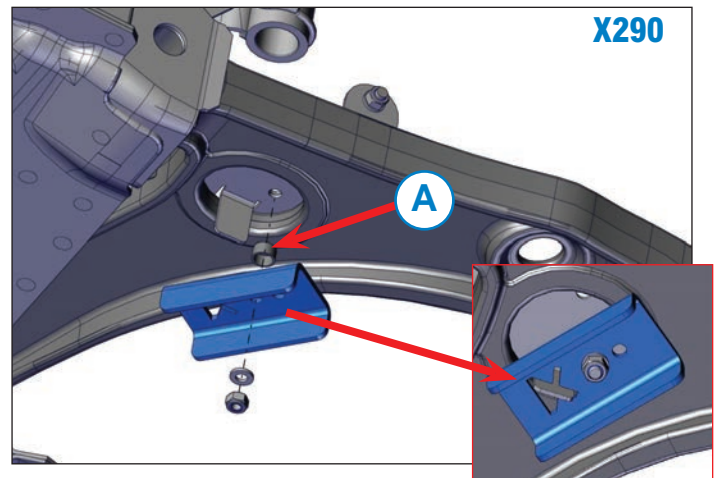

- | | |
|-------------------|---------|
| 2 x bolt | M6 x 30 |
| 4 x washer | M6 |
| 2 x lock nut | M6 |
| 2 x distance bush | |



8 Nm

14. Check the length of the height sensor rods **165 mm** - measured centre to centre.
15. Mount the height sensor rods on the height sensors and ball joints.
16. Secure the height sensor rods by pushing in the clips.

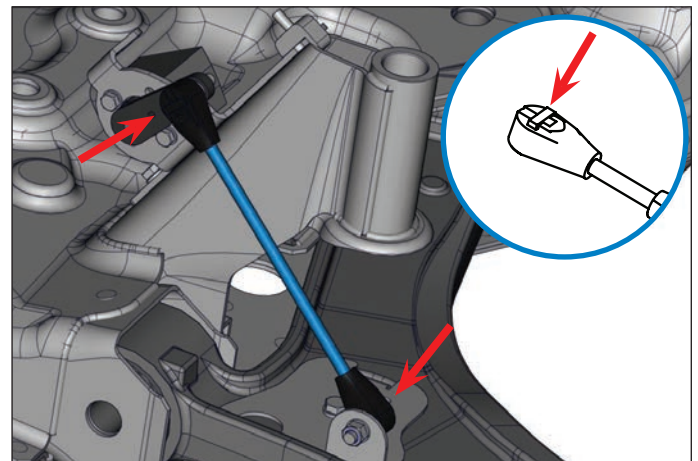

The height sensor arms must point up.

17. Connect the front axle height sensor cable using the connector marked in brown.
18. Route the tubes to the compressor box.
19. Route the left height sensor cable along the **blue** air tube to the front left height sensor.
20. Route the right height sensor cable along the **red** air tube to the front right height sensor.
21. Connect the connectors. The illustration is for indicative purposes only for showing the height sensor cable mounting bracket.
22. Fit the wheels.

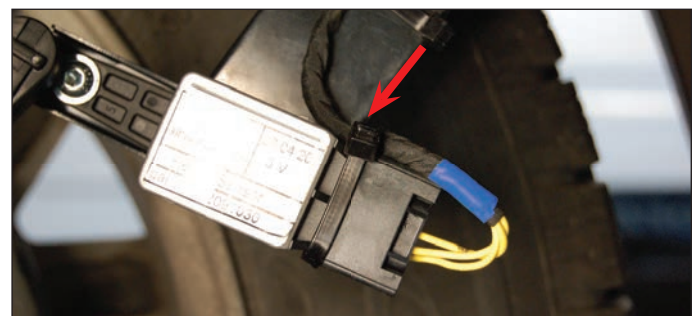

15" wheels



160 Nm

16" wheels



180 Nm

6.4 Air tubes

1. Fit the **red** air tube to the air coupling marked red on the junction block on the outside of the compressor box.
2. Fit the **blue** air tube to the air coupling marked blue on the junction block on the outside of the compressor box.
3. Ensure that the colour markings match.
4. Seal the unused air couplings with the supplied end plugs.
5. If kit 105 16 01 4XX for the front and rear axle has been fitted, continue from section **7.3**.

Air couplings for emergency valve kit (optional)

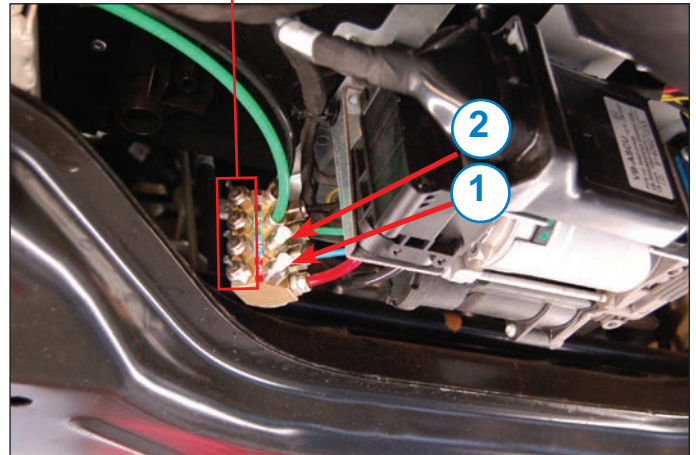

6.5 Warranty stickers

1. Affix the supplied warranty stickers **A + B** to the B-pillar on the passenger's side.
2. Affix sticker **B** to the compressor box next to the part number sticker.



A



B

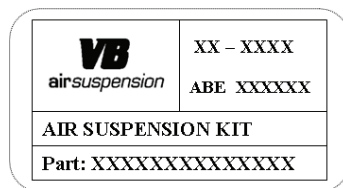

7. Calibration

See document [730 105 000 001 Fitting Instructions calibration VB-FA 2C 4C](#) for the general calibration steps.

Vehicle-specific steps are detailed below.



Go to chapter 2 for details of the correct calibration supports for this kit.

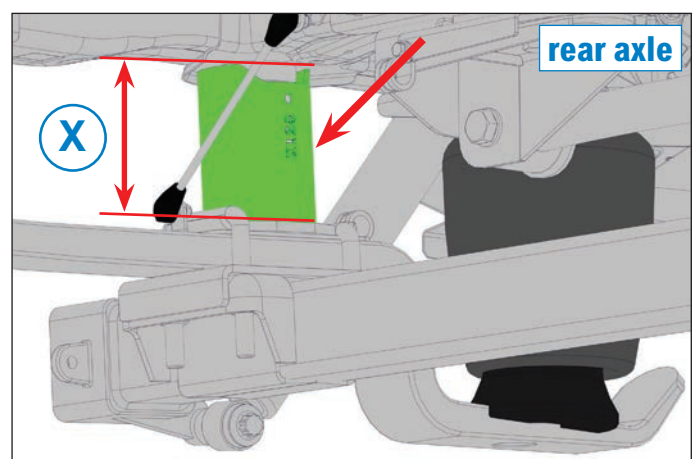
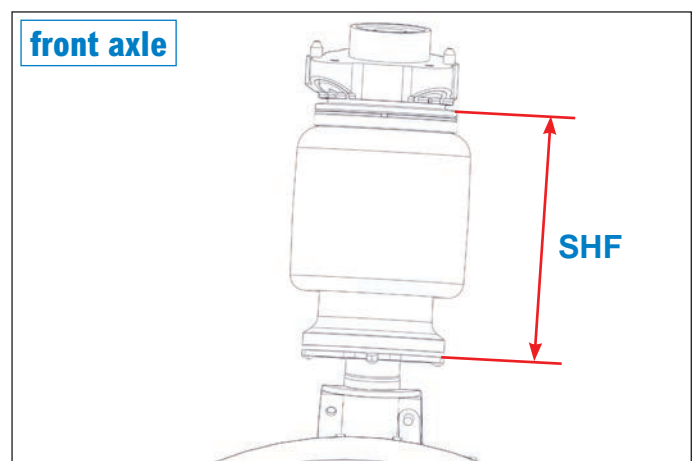
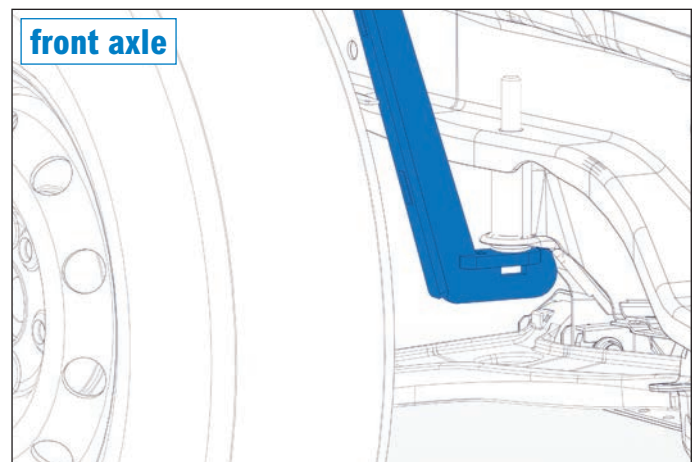
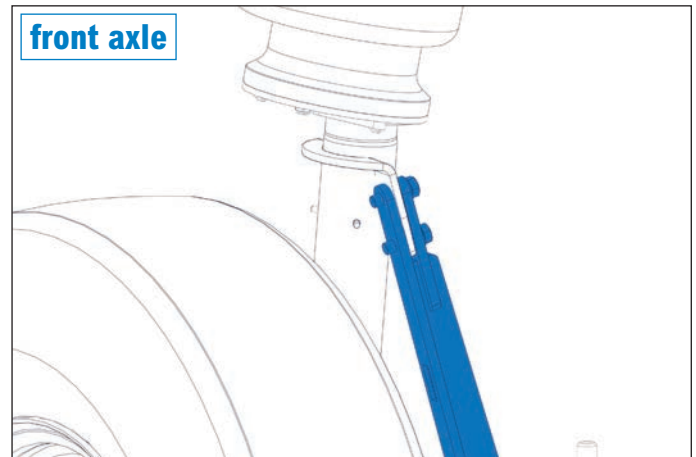

8. Checklist

8.1 Final checks

	<i>OK</i>
1.1 Ride height correctly calibrated.	<input type="checkbox"/>
1.2 Front axle/rear axle aligned.	<input type="checkbox"/>
1.3 Height sensors correctly fitted.	<input type="checkbox"/>
1.4 Shock absorbers vented.	<input type="checkbox"/>
1.5 Bolts tightened to correct torque and ticked off.	<input type="checkbox"/>
1.6 Air tubes, wires and connectors properly secured.	<input type="checkbox"/>
1.7 System checked for air tightness.	<input type="checkbox"/>
1.8 Clearance around air springs checked.	<input type="checkbox"/>
1.9 Headlamp adjustment checked.	<input type="checkbox"/>
1.10 Documentation present.	<input type="checkbox"/>
1.11 Warranty form completed and identification stickers affixed to vehicle.	<input type="checkbox"/>

8.2 System functions

	<i>OK</i>
2.1 Raise manually.	<input type="checkbox"/>
2.2 Lower automatically.	<input type="checkbox"/>
2.3 Lower manually.	<input type="checkbox"/>
2.4 Raise automatically.	<input type="checkbox"/>
2.5 Test drive carried out.	<input type="checkbox"/>

SYSTEM OK

9. Appendix, other signals when Euro 4 model factory option is not present

9.1 Speed signal

1. Remove the blue connector from the fuse box.



2. This connector has a black and a grey section
3. Remove the grey/green wire in position ten on the grey part.

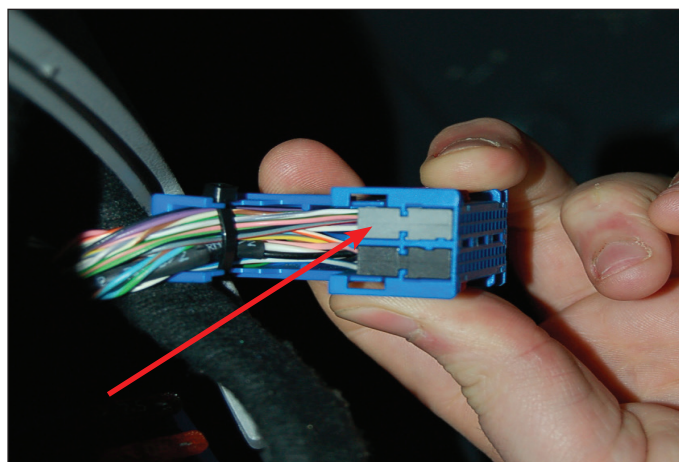

4. Remove the terminal from yellow cable no. 18 from the VB supply cable.
5. Using the red connector, connect yellow wire no. 18 to the grey/green speed signal wire.



9.2 15+ signal

1. There is a connector on the rear of the fuse box.
2. The thick, blue wire is a positive contact.
3. Take the round terminal off the supply cable.
4. Connect the pink wire to the blue connector on the thick blue wire.

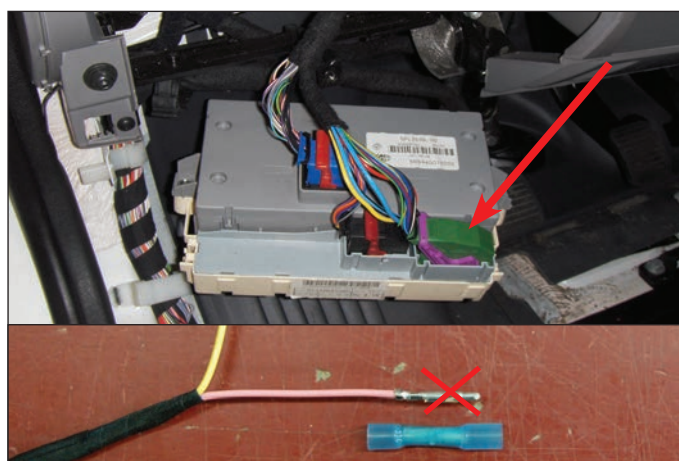

10. Appendix, other signals when Euro 5 model factory option is not present

10.1 Speed signal

1. Remove the black connector from the fuse box.

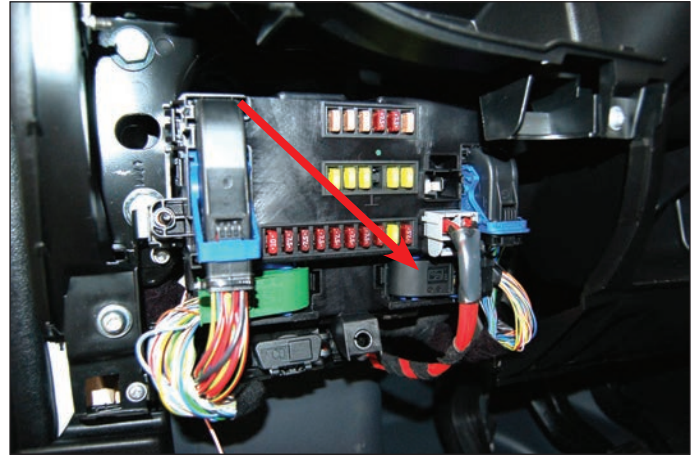

2. Pin 56 contains the speed signal.

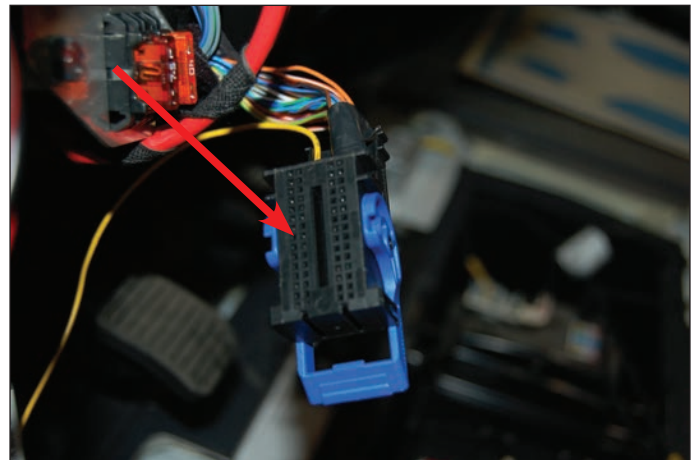

3. Remove the terminal from yellow cable no. 18 from the VB supply cable.
4. Fit the wire with terminal (A) with the red connector (B) to the yellow supply cable wire (C).
5. Place the terminal of yellow wire no.18 in the location of pin 56 in the connector.

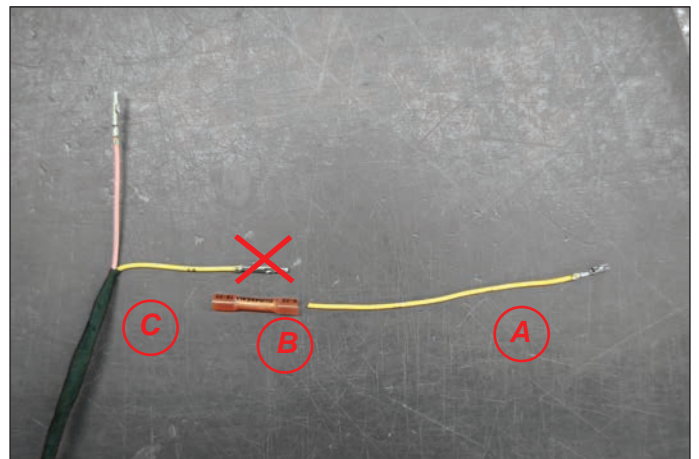

If this location is occupied, remove the terminal. Using the red connector, connect yellow wire no. 18 to the wire on pin 56.

10.2 15+ signal



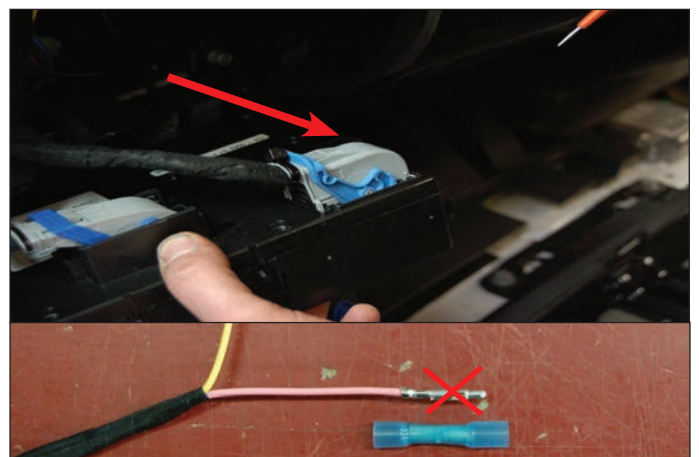

1. There is a connector on the rear of the fuse box.
2. The thick, blue wire is a positive contact.
3. Take the round terminal off the supply cable.
4. Connect the pink wire to the blue connector on the thick blue wire.

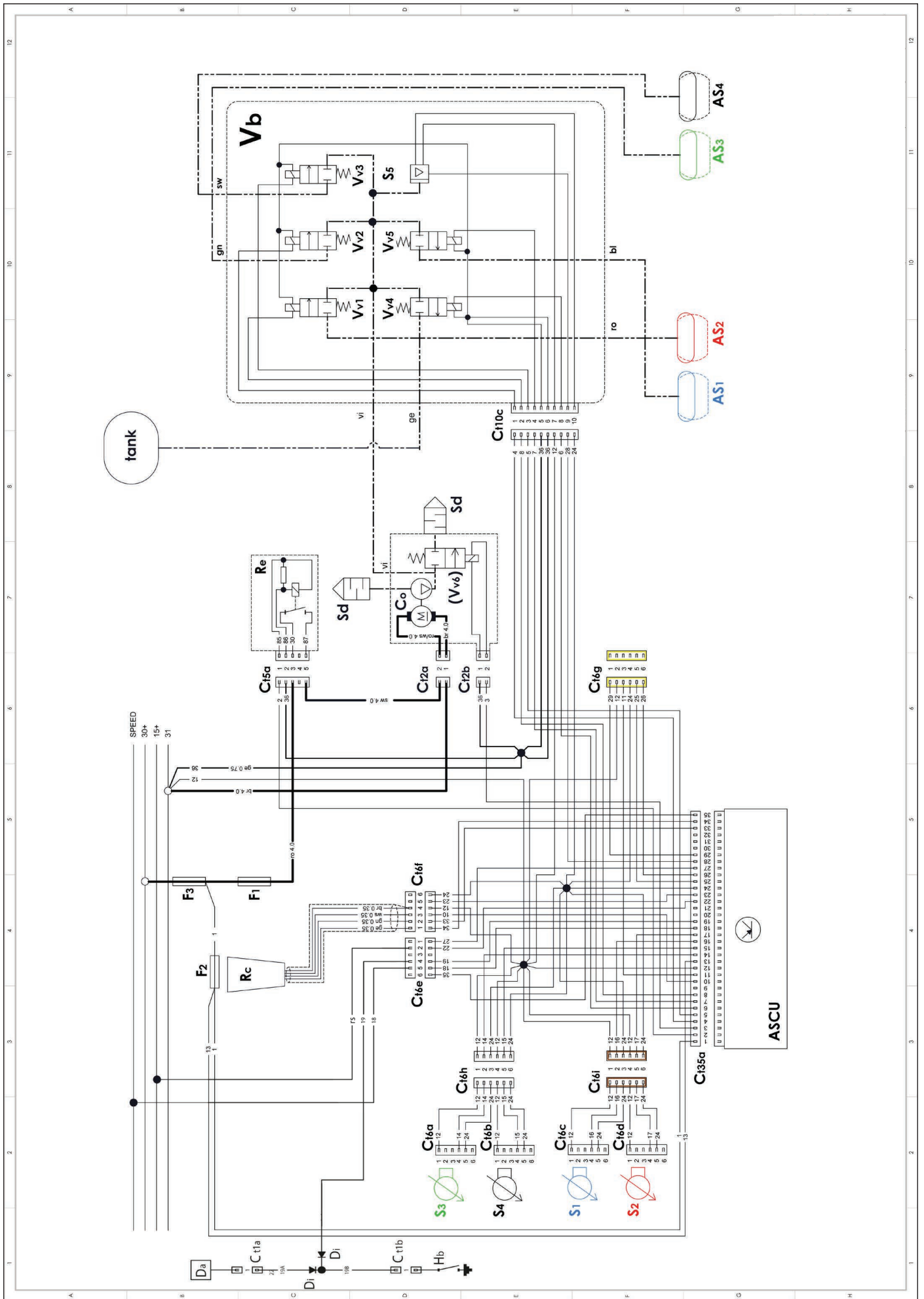

11. Electrical diagram



Name	Description
ASCU	VB-ASCU (electronic control unit)
AS1	Air spring, front left
AS2	Air spring, front right
AS3	Air spring, rear left
AS4	Air spring, rear right
Ct2a	Connector, 2-pin, compressor power supply
Ct2b	Connector, 2-pin, dump valve on compressor
Ct5a	Connector, 5-pin, compressor relay
Ct6a	Connector, 6-pin, height sensor rear left
Tc6b	Connector, 6-pin, height sensor rear right
Ct6c	Connector, 6-pin, height sensor front left
Ct6d	Connector, 6-pin, height sensor front right
Ct6e	Connector, 6-pin, VB supply cable
Ct6f	Connector, 6-pin, remote control
Ct6g	Connector, 6-pin, connector option (yellow)
Ct6h	Connector, 6-pin, rear axle height sensors (white)
Ct6i	Connector, 6-pin, front axle height sensors (brown)
Ct10c	Connector, 10-pin, valve block
Ct35a	Connector, 35-pin, VB-ASCU
Co	Compressor
Ds	End plug
F1	Fuse, compressor, 40 A
F2	Fuse, VB-ASCU, 7.5 A
F3	Fuse, primary, 50 A
Re	Compressor relay
Rc	Remote control
S1	Height sensor, front left
S2	Height sensor, front right
S3	Height sensor, rear left
S4	Height sensor, rear right
S5	Pressure sensor on valve block
Sd	Air silencer/filter
Tank	Air tank
Vb	Valve block
Vv1	Valve for front right air spring on valve block
Vv2	Valve for rear left air spring on valve block
Vv3	Valve for rear right air spring on valve block
Vv4	Dump valve to vent air on valve block
Vv5	Valve for front left air spring on valve block
Vv6	Dump valve on compressor

Name	Description
Colour codes (yellow with wire number is not indicated)	
bl	Blue
br	Brown
ge	Yellow
gn	Green
ro	Red
ro/ws	Red/white
rs	Pink
sw	Black
vi	Purple
ws	White
	0.50 mm ²
	0.75 mm ²
	4.00 mm ²
	Air tube



VB-Airsuspension is one of the few European manufacturers producing a wide range of (air) suspension systems. From semi air suspension and reinforced coil springs to complete, comprehensive air suspension systems: we offer our customers solutions for various vehicles, such as emergency vehicles, car transporters, motorhomes etc. Now you can see why an increasing number of truck and body manufacturers are incorporating VB-Airsuspension's systems in their own ranges.



Dealer:



VB

airsuspension



www.vbairsuspension.com